

## CONTENTS

1.	Introduction.....	199
2.	Clinical Roadmap Projects.....	201
2.1	Stochastic Tractography for VCFS.....	201
2.2	Brain Lesion Analysis in Neuropsychiatric Systemic Lupus Erythematosus.....	205
2.3	Cortical Thickness for Autism.....	208
2.4	Needle-Positioning Robot Integration for MR-Guided Prostate Biopsy.....	211
3.	Four Infrastructure Topics.....	215
3.1	Diffusion Image Analysis Theme.....	215
3.2	Structural Analysis Theme.....	220
3.3	fMRI Analysis Theme.....	224
3.4	NA-MIC Kit Theme.....	225
4.	Highlights.....	228
4.1	Advanced Algorithms.....	228
4.2	NA-MIC Kit.....	229
4.3	Outreach and Technology Transfer.....	229
4.4	Tutorial for Autism DBP: Cortical Thickness Measurement.....	230
5.	Impact and Value to Biocomputing.....	231
5.1	Impact within the Center.....	231
5.2	Impact within NIH-Funded Research.....	232
5.3	National and International Impact.....	233
6.	Timelines.....	234
6.1	Core 1: Algorithms.....	234
6.2	Core 2: Engineering.....	236
6.3	Core 3: Driving Biological Problems.....	238
6.4	Core 4: Service.....	238
6.5	Core 5: Training.....	239
6.6	Core 6: Dissemination.....	239
7.	Appendix A: Publications.....	241
8.	Appendix B: EAB Report and Response.....	246

## **NATIONAL ALLIANCE FOR MEDICAL IMAGING COMPUTING Annual Progress Report 2008-2009**

### **I. INTRODUCTION**

The National Alliance for Medical Imaging Computing (NA-MIC) is now completing its fifth year. The Center is comprised of a multi-institutional, interdisciplinary team of computer scientists, software engineers, and medical investigators who have come together to develop and apply computational tools for the analysis and visualization of medical imaging data. A further purpose of the Center is to provide infrastructure and environmental support for the development of computational algorithms and open source technologies, as well as to oversee the training and dissemination of these tools to the medical research community. We are currently in year two of our second set of Driving Biological Projects (DBP), three of which involve diseases of the brain: (1) stochastic tractography for velocardio-facial syndrome (VCFS); (2) brain lesion analysis in neuropsychiatric systemic lupus erythematosus; and (3) a study of cortical thickness for autism. The fourth (4) DBP takes the Center in a completely new direction with a study on robot integration of needle positioning in percutaneous brachytherapy for prostate cancer.

Over the past five years, NA-MIC has made substantial progress toward the attainment of its major objectives. In year one, the Center focused on forging alliances amongst its various cores and constituent groups to assure that the efforts of the cores were well integrated toward the attainment of common and specific goals. To that end a great deal of effort went into defining the kinds of tools that would be needed for specific imaging applications. Year two emphasized the identification of key research thrusts that cut across all cores and were driven by the needs and requirements of the DBPs. This led to the formulation of the Center's four main technical themes: Diffusion Tensor Analysis, Structural Analysis, Functional MRI Analysis, and the integration of newly developed tools into the NA-MIC Tool Kit. Year three of Center activity was devoted to the continuation of collaborative work to develop solutions for the various brain-oriented DBPs. Year four was focused on translating collaborative knowledge and work to a new set of DBPs. In the current fifth year, a number of projects have made sufficient progress to warrant introduction as modules in Slicer, thereby making the Core 1 algorithms available to the general medical imaging community. Some of these algorithms are quite general and can be used for purposes far broader than the original DBPs. For example, a new point cloud registration algorithm developed for the prostate brachytherapy needle positioning project also can be used for DWI registration. Likewise, work on DTI/DWI tractography has been applied to the segmentation of blood vessels and soft plaque detection in the coronary arteries.

Year five progress with respect to the current DBPs is relevant to the scope of this Annual Progress Report. As mentioned, we currently have three projects in the area of neuropsychiatric disorders: Systemic Lupus Erythematosus (Mind Institute, University of New Mexico), Velocardiofacial Syndrome (Harvard), and Autism (University of North Carolina, Chapel Hill). A fourth project from Johns Hopkins and Queens Universities involves the application of core technologies to imaging/robotics-guided treatments in prostate cancer. A number of papers have been published that specifically acknowledge the NA-MIC, and significant software development is continuing as well.

Section 2 outlines specific aims fulfilled this year by the four roadmap projects: Section 2.1 describes the Stochastic Tractography Approach for Velocardiofacial Syndrome; Section 2.2 outlines the Brain Lesion Analysis in Neuropsychiatric Systemic Lupus Erythematosus project; Section 2.3 documents the Cortical Thickness for Autism project and Section 2.4 details the application of our work in Brachytherapy Needle Positioning for the Prostate; For all of these projects, a synergism of effort has produced working computer modules that are user friendly and accessible to both medical researchers and clinicians.

Section 3 describes year five work on the four infrastructure topics. These include: Diffusion Image Analysis (Section 3.1), Structural Analysis (Section 3.2), Functional MRI Analysis (Section 3.3), and the NA-MIC Toolkit (Section 3.4). Many of the algorithms produced by Cores 1-3 have been integrated into ITK and Slicer, including those concerning shape analysis (e.g., spherical wavelets), new segmentation algorithms (for DTI/DWI tractography and the segmentation of the prostate), and new approaches to registration (e.g., based on particle filtering).

Finally, the last three sections highlights work identified by the Scientific Leadership to be particularly significant to the overall goals of the Center. Section 4 summarizes the benefits of several advanced algorithms, gives a description of the growing NAMIC-Toolkit, and documents the scope of our efforts in technology transfer and outreach. It is essential to emphasize that although the algorithms emanating from this Center were developed to solve specific clinical problems raised by the DBPs, in application, most of these algorithms have far more general utility and far greater potential to impact the medical imaging technical base. To this end, Section 5 draws attention to the impact and value of our work on biocomputing imaging at three different levels: within the Center, within the NIH-funded research community, and externally to the national and international community. To further illustrate the impact of our work, Section 6 provides some updated timelines that specify milestones achieved by the various NA-MIC cores. Section 7 contains an Appendix of publications pertinent to the current reporting period that acknowledge NA-MIC support, and Section 8 appends the External Advisory Report along with the Center's considered response.

This year has been witness to the addition of an increasing number of end-to-end workflows in the NA-MIC Kit. Workflows are groups of modules that, when integrated, produce complex segmentation, registration, and biomedical computing algorithms. These workflows are defined by the needs of the clinical roadmap projects described above. Each DBP has selected specific workflows and roadmaps that highlight focal needs that can be fulfilled by end-to-end solutions using NA-MIC tools. In turn, NA-MIC drives the development of its platforms and algorithms through the research of the DBPs.

## 2. CLINICAL ROADMAP PROJECTS

### 2.1 Stochastic Tractography for Velocardio-facial Syndrome

#### Key Investigators

**Marek Kubicki**, PI, Harvard Medical School, Psychiatry Neuroimaging Laboratory (PNL), Department of Psychiatry, Brigham and Women's Hospital

**Brad Davis**, Kitware, NA-MIC Engineering Core

**Polina Golland**, CSAIL, MIT, NA-MIC Algorithms Core

**Host Institutions:** Harvard Medical School, Brigham and Women's Hospital

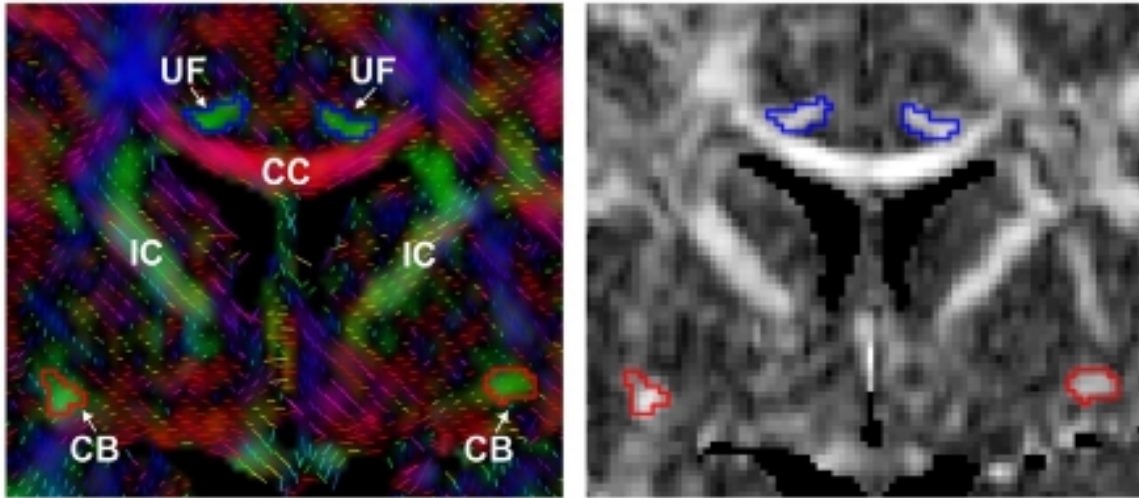

**Figure 1.** Kawashima T, Nakamura M, Bouix S, Kubicki M, Salisbury D, Westin C, McCarley R, Shenton M. Uncinate fasciculus abnormalities in recent onset schizophrenia and affective psychosis: A diffusion tensor imaging study. *Schizophr Res.* 2009 May;110(1-3):119-126. PMID: 19328656.

#### Overview

The goal of this project is to create an end-to-end workflow application for evaluating the anatomical connectivity between segmented cortical regions of the brain. The overall goal of the project is to increase understanding of the similarities and differences in anatomical connectivity between schizophrenia and velocardio-facial syndrome (VCFS). VCFS is a genetic disorder characterized by a deletion of a small piece of chromosome-22, the same chromosome associated with schizophrenia. The features of this syndrome include deficits in neurological psychomotor and perceptual skills, as well as cognitive domains such as learning and memory. A unique aspect of this syndrome is that up to 30% of patients with VCFS develop schizophrenia, making it the most common risk factor for the development of psychosis and an ideal model for studying the neurodevelopmental changes that lead to psychotic deficits. We plan to use Stochastic Tractography to analyze abnormalities in integrity or connectivity in the arcuate fasciculus fiber bundle. This region of the brain is involved in language processing in both schizophrenia and VCFS.

### **Algorithm Component**

The core science involved in this project, known as the Stochastic Tractography algorithm, was developed and implemented collaboratively by MIT and BWH. Stochastic Tractography is a Bayesian approach to estimating nerve fiber tracts from images created by diffusion tensor imaging (DTI).

In this approach, the diffusion tensor is used at each voxel in the volume to construct a local probability distribution for the fiber direction around the principal direction of diffusion. The tracts then are sampled between two user-selected regions of interest (ROIs) by simulating a random walk between the regions, based on the local transition probabilities inferred from the DTI image.

The resulting collection of fibers and the associated functional anisotropy (FA) values provide useful statistics on the properties of the connections between the two regions. To constrain the sampling process to the relevant white matter region, atlas-based segmentation is used to label ventricles and gray matter, thereby excluding them from the search space. This latter step relies heavily on the Registration and Segmentation functionality of Slicer.

Over the last year, we have been working to apply several pre- and postprocessing steps to the algorithm pipeline. These steps include Eddy Current and Geometric Distortion Correction, both made available to us by the Utah group, as well as DTI Filtering from BWH. White matter masks now also can be created based on T2 thresholding within the Slicer Stochastic Tractography module. These masks are more precise, as they do not rely on MRI-to-DTI co-registration.

We also have been working on the datasets that apply to situations where fMRI activations as well as gray matter segmentations need to be registered to DTI data in order to permit seeding within predefined gray matter regions. Significant progress has been made in modality registration, and additional improvement is expected when Geometric Distortion Correction becomes part of the analysis pipeline.

Finally, we have been working on ways to improve the visualization and quantification of Stochastic Tractography output, not only by parametrizing fiber tracts, but also by creating connection probability distribution maps.

### **Engineering Component**

This year, in anticipation of the release of Slicer 3, Engineering Core rewrote the Stochastic Tractography Slicer module in Python. The new module was released in December 2008, and presented at the "All Hands Meeting" in Salt Lake City, Utah. The module now is a functional component of Slicer3. Documentation for operating the module also has been created to facilitate user training. Current engineering efforts are focused on maintaining the module, optimizing the module for use with other data formats, and adding new functionality, such as better registration, distortion correction, and methods for extracting and measuring FA along nerve fiber tracts.

Special emphasis has been placed on the following important tasks:

The datasets used with the Stochastic Tractography module are computationally demanding. They involve higher spatial resolutions and many more diffusion directions than white matter tractography, with which we have previous experience. As well, the

cortical ROIs tend to be much larger than white matter ROIs. Hence, there is a pressing need for performance improvement. This need can be appreciated by examining the differences between Stochastic Tractography, where literally hundreds of tracts are generated from a single seed, and Deterministic Tractography, where only a single tract is generated. Thus, some effort has been made to economize by using multi-threading and parallel processing to reduce this burden. A version of the Stochastic Tractography algorithm that uses large computer clusters also has been developed and can be downloaded and installed by individual users with minimal knowledge of parallel computing.

### **Clinical Component**

This reporting period has seen the design, implementation, or completion of several clinical studies that test the Stochastic Tractography algorithm on the newly released 3T NA-MIC data. These data were acquired on the new 3T magnet (General Electric Medical Systems, Milwaukee, WI) at BWH. These datasets consist of high resolution DTI, structural MR data, and automatic anatomical segmentations. Since these data already have been co-registered, cortical ROIs can be used as seeding points for Stochastic Tractography.

The first of these clinical studies proposes to analyze the connections between the inferior frontal and superior temporal lobes, both of which represent important sites of the language network. The connections between these two regions were measured via Stochastic Tractography in a group of 20 chronic schizophrenia patients and 20 controls and then subjected to comparative analysis. We also examined gray matter volume in destination regions and attempted to estimate the relationship between gray and white matter abnormalities in schizophrenia. The results of this study were presented at the World Psychiatry Congress in Florence, Italy in April, 2009, and later that same month at the Harvard Psychiatry MYSELL conference.

Another current endeavor is the use of Stochastic Tractography to define the connections involved in emotional processing. For this study, we are using cortical segmentations of the anterior cingulate gyrus, orbital-frontal gyrus, and amygdala to trace as well as quantify their interconnections in healthy controls versus schizophrenia patients. The results of this preliminary study were presented at MYSELL in April 2009. Another presentation will be made at the Biological Psychiatry conference later this year.

We also have been involved in two collaborative efforts. The first involves the use of DTI data that was acquired at University of California-Irvine (UCI). In this study, we have used Stochastic Tractography to segment and measure the arcuate fasciculus in subjects with schizophrenia and language impairment, as evidenced in event-related potential (ERP) data. In a second collaboration, we are combining resting state fMRI data with DTI to measure connectivity between regions that form a functional network. Both of these projects are currently under way.

Finally, a paper that discusses the qualitative use of Stochastic Tractography has been accepted for publication in *Human Brain Mapping* and is currently in press. Here, when we combined fMRI with DTI whole brain data analysis, we identified certain regions that expressed abnormal functional connectivity in schizophrenia. These regions then were assigned to certain anatomical structures (white matter tracts) based on their location and relationship to the Stochastic Tractography output.

**Additional information is available on the NA-MIC wiki.**

<http://wiki.na-mic.org/Wiki/index.php/DBP2:Harvard>

## PAPERS AND PRESENTATIONS

### ***Peer-reviewed articles in journals***

Kawashima T., Nakamura M., Bouix S., Kubicki M., Salisbury D., Westin C., McCarley R., Shenton M. Uncinate fasciculus abnormalities in recent onset schizophrenia and affective psychosis: A diffusion tensor imaging study. *Schizophr Res.* 2009 May;110(1-3):119-126. PMID: 19328656.

Kubicki M., Styner M., Bouix S., Gerig G., Markant D., Smith K., Kikinis R., McCarley R., Shenton M. Reduced interhemispheric connectivity in schizophrenia-tractography based segmentation of the corpus callosum. *Schizophr Res.* 2008 Dec;106(2-3):125-31. PMID: 18829262.

Lee K., Yoshida T., Kubicki M., Bouix S., Westin C., Kindlmann G., Niznikiewicz M., Cohen A., McCarley R., Shenton M. Increased diffusivity in superior temporal gyrus in patients with schizophrenia: A Diffusion Tensor Imaging study. *Schizophr Res.* 2009 Mar;108(1-3):33-40. PMID: 19135872.

Fitzsimmons J., Kubicki M., Smith K., Bushell G., San José Estepar R., Westin C., Nestor P., Niznikiewicz M., Kikinis R., McCarley R., Shenton M. Diffusion tractography of the fornix in schizophrenia. *Schizophr Res* 2009 Jan; 107:39–46. PMID: 19046624.

### ***Peer-reviewed full length articles in conference proceedings***

Mohan V., Sundaramoorthi G., Melonakos J., Niethammer M., Kubicki M., Tannenbaum A. Tubular Surface Evolution for Segmentation of the Cingulum Bundle From DW-MRI. Proceedings of the Second Workshop on Mathematical Foundations of Computational Anatomy (MFCA'08), Int Conf Med Image Comput Comput Assist Interv. 2008.

Aja-Fernandez S., Niethammer M., Kubicki M., Shenton M., Westin C. Restoration of DWI data using a Rician LMMSE estimator. *IEEE Trans Med Imaging.* 2008 Oct;27(10):1389-403. PMID: 18815091.

## 2.2 Roadmap Project: Brain Lesion Analysis in Neuropsychiatric Systemic Lupus Erythematosus

### Key Investigators

**H Jeremy Bockholt**, Co-PI, Mind Research Network

**Charles Gasparovic**, Co-PI, University of New Mexico

**Mark Scully**, Software engineer, Mind

**Steve Pieper**, NA-MIC Engineering, Isomics

**Ross Whitaker**, NA-MIC Algorithms, Utah

**Host Institutions:** The Mind Institute and The University of New Mexico

### WHITE MATTER LESION ANALYSIS IN NSLE

**Registration:** Co-registration of T1-weighted, T2-weighted, and FLAIR images

**Tissue segmentation:** Multi-modality, with correction for intensity inhomogeneity and work on non-skull-stripped data.

**Lesion Localization:** Each unique lesion detected and anatomical location summarized.

**Lesion Load Measurement:** Volume of each lesion measured, lesion load summarized by regions.

**Tutorial:** Documentation for a tutorial and sample datasets.

**Figure 2.** Steps in the end-to-end application for the NA-MIC Kit.

### Overview

The primary goal of the Mind Institute DPB is to examine changes in white matter lesions in adults with neuropsychiatric systemic lupus erythematosus (NSLE). Our aim is to characterize lesions with respect to location, size, and intensity, and then to examine the longitudinal changes of these lesions in an SLE cohort. To accomplish these goals, we have created an end-to-end application entirely within the NA-MIC Kit that allows individual analysis of white matter lesions. This workflow then will be applied to a clinical sample that is currently being acquired.

### Algorithm Component

The application for white matter lesion analysis comprises the following basic steps: (1) registration of T1, T2, and FLAIR images; (2) classification of tissue as gray matter, white matter, CSF, or lesion; (3) lesion clustering for anatomical localization; and (4) summarization of lesion size and image intensity parameters within each unique lesion.

During this reporting interval, we have improved the Morphometric Feature-based Segmentation method by incorporating maximum relevancy, minimum redundancy



feature ranking, and support vector machine-based classification. Additionally, the new method produces a heat map, where each voxel value represents the chance of that voxel belonging to the lesion. The heat map allows the user to adjust the threshold used for segmentation to match the user's sensitivity /specificity preferences.

### **Engineering Component**

At the January 2009 Winter Project Week, a first pass of the lesion segmentation tutorial was provided to the community week [http://www.na-mic.org/Wiki/index.php/2009\\_Winter\\_Project\\_Week](http://www.na-mic.org/Wiki/index.php/2009_Winter_Project_Week). This tutorial was the first end-to-end workflow for this project and represents a significant step forward. On the basis of feedback from the community and the target clinical users of these tools, we identified several additional steps to improve the system. These are summarized below.

**Interface Improvements:** We have begun to look at the possibility of creating a high level wizard as a front end to the processing task. This interface would permit users to go through the steps without directly navigating the Slicer modules and also would provide state management to simplify the visualization efforts. More information about this interface is available on the NA-MIC wiki. [http://www.na-mic.org/Wiki/index.php/2009\\_Winter\\_Project\\_Week:HighLevelWizard](http://www.na-mic.org/Wiki/index.php/2009_Winter_Project_Week:HighLevelWizard)

**Modularity and Deployment:** We have received feedback from some users that the current tutorial is difficult to implement because the Lesion Detection module currently must be compiled locally on the user's machine. Non-developers, in particular, find this to be a difficult requirement. Consequently, we are integrating the lesion segmentation code into the Slicer3 loadable module project to make pre-compiled versions of the module available to users. More information about this module is available on the NA-MIC wiki. [http://www.slicer.org/slicerWiki/index.php/Slicer3:Loadable\\_Modules:Status](http://www.slicer.org/slicerWiki/index.php/Slicer3:Loadable_Modules:Status)

To implement this plan, we are following the templates provided by the Slicer example modules available on the Neuroimaging Informatics Tools and Resources Clearinghouse (NITRC) which can be accessed on line. <http://www.nitrc.org/projects/slicer3examples/> This infrastructure was created by a supplement to NA-MIC provided by the NITRC project. The project page on nitrc.org is updated as new features are added to the modules. <http://www.nitrc.org/projects/lupuslesion>

**Core Implementation Support:** During this period we also have worked on implementation of the core ITK code. More information is available on the NA-MIC wiki. [http://www.na-mic.org/Wiki/index.php/2009\\_Winter\\_Project\\_Week:LesionSegmentationEfficiency](http://www.na-mic.org/Wiki/index.php/2009_Winter_Project_Week:LesionSegmentationEfficiency)

This effort has primarily been accomplished by the Mind Institute group, with interactions as needed with the rest of the NA-MIC community.

In addition, we are having ongoing discussions with the rest of the NA-MIC community to encourage code sharing among projects through modularization of common processing tasks and development of 'best of breed' routines for lesion detection and quantification. These tools then are embodied as Slicer modules for use in other applications, such as brain tumor change tracking.

### **Clinical Component**

During the past year, the Mind team attended MICCAI / and participated in the MICCAI MS lesion challenge. We collected all data for 5 lupus lesion subjects and publicly shared the dataset on the NITRC website. We researched and developed a novel morphometric feature-based approach to lesion segmentation using a Naive Bayes classifier. This approach was released as a Slicer3 plugin to perform lupus lesion segmentation using the novel method.

After the clinical application of the morphometric feature-based approach was made available and we received some user feedback, we decided to further enhance the approach. The resulting new LupusLesion clinical application (described in the algorithm enhancements above) now has been tested on a clinical SLE dataset of 20 individuals independent of the training dataset. Results obtained from a receiver operator characteristic (ROC) curve when testing the application of the method to novel cases showed a trade-off between sensitivity and specificity with the best combination at sensitivity of 0.86 and 0.01 for (1- Specificity).

A new version of the Slicer3 LupusLesion clinical application module that uses the improved morphometric feature method is planned for release on or before the 2009 NA-MIC programming week.

During the past year we have prepared a methods paper for submission and presented our methods work at conferences. We also have prepared a clinical paper summarizing the application of the method to a clinical SLE population. Finally, we conducted a formal dissemination event during the 2008 Society for Neuroscience Annual meeting, where we provided a hands-on tutorial for using the LupusLesion clinical application. We have a second dissemination event planned for an upcoming annual Neurovascular meeting.

### **PAPERS AND PRESENTATIONS**

#### ***Peer-reviewed full length articles in conference proceedings***

Scully M., Magnotta V., Gasparovic C., Pelligrino P., Feis D., Bockholt H.J. 3D Segmentation In The Clinic: A Grand Challenge II at MICCAI 2008 - MS Lesion Segmentation. IJ - 2008 MICCAI Workshop - MS Lesion Segmentation. Available HYPERLINK "<http://hdl.handle.net/10380/1449>"  
<http://hdl.handle.net/10380/1449>

Bockholt H.J., Magnotta V.A., Scully M., Gasparovic C., Davis B., Pohl K., Whitaker R., Pieper S., Roldan C., Jung R., Hayek R., Sibbitt W., Sharrar J., Pellegrino P., Kikinis R. A novel automated method for classification of white matter lesions in systemic lupus erythematosus. Presented at the 38th annual meeting of the Society for Neuroscience, Washington, DC, 15 – 19 November 2008

**Additional information is available on the NA-MIC wiki.**

<http://wiki.na-mic.org/Wiki/index.php/DBP2:MIND:Roadmap>

## 2.3 Roadmap Project: Cortical Thickness for Autism

### Key Investigators

**Heather Cody Hazlett**, CO-PI

**Joseph Piven**, CO-PI

**Jim Miller**, NA-MIC Engineering, GE Research

**Martin Styner**, NA-MIC Algorithms, UNC

**Host Institution:** University of North Carolina

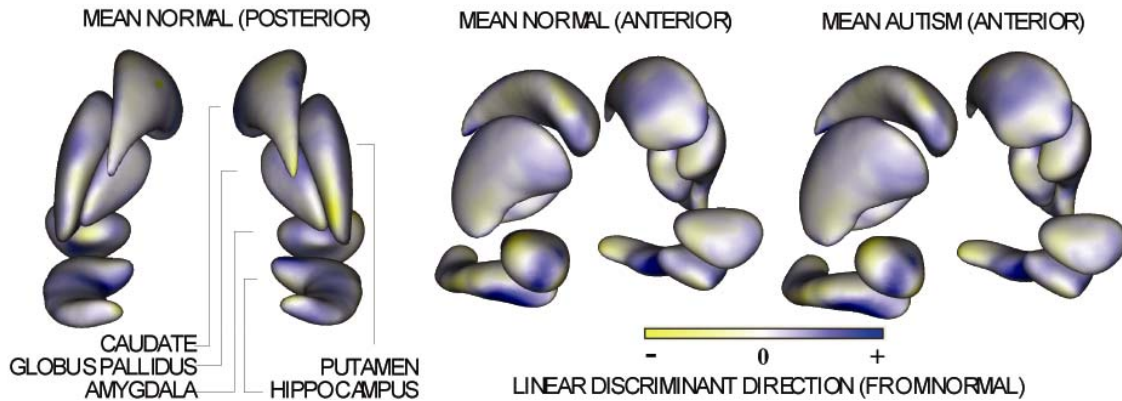

**Figure 3.** Cates J., Fletcher P., Styner M., Hazlett H., Whitaker R. Particle-Based Shape Analysis of Multi-object Complexes. *Int Conf Med Image Comput Comput Assist Interv.* 2008;11(Pt 1):477-485. PMID: 18979781.

### Overview

A primary goal of the DPB at University of North Carolina (UNC) is to examine changes in cortical thickness in children with autism and compare them with typical controls. Our goal is to examine group differences in both local and regional cortical thickness. We also wish to examine longitudinal changes in the cortex in children between the ages of 2 and 4 years. To accomplish this goal, this project will create an end-to-end application within Slicer3 that permits individual and group analysis of regional and local cortical thickness. Such workflow then will be applied to our study data (already collected).

We have developed a specific project for our NA-MIC DBP focused on the goal of obtaining regional and local cortical thickness measurements on our pediatric dataset. A secondary goal is to incorporate this measurement module into the NA-MIC toolkit application, Slicer3. After these preliminary goals have been accomplished, the module will be compared to other existing cortical thickness methods (e.g., FreeSurfer).

### Algorithm and Engineering

The basic steps necessary for the cortical thickness application are (1) tissue segmentation to separate white and gray matter regions; (2) cortical thickness measurement; (3) cortical correspondence to compare measurements across subjects; and (4) a statistical analysis to locally compute group differences. Integral to this project, is the creation of end-to-end applications that allow individual and group analysis of regional and local cortical thickness. The regional and local cortical thickness analysis is

based on separate pipelines and work in these areas is described below.

**Regional:** A Slicer3 high-level module that performs individual regional cortical thickness analysis was completed this past year, called ARCTIC (Automatic Regional Cortical ThICkness). The basic default steps entail (1) probabilistic atlas-based automatic tissue segmentation; (2) atlas parcellation deformable registration; and (3) asymmetric cortical thickness measurement. The user is permitted to skip some of these steps, if related images, such as tissue segmentation label maps or parcellation maps, are provided. This application provides not only lobar cortical thickness measurements but also tissue segmentation volume information, which is stored in spreadsheets. Moreover, a quick quality control can be performed for each step within Slicer3 by using a MRML scene that displays output volumes and surfaces. ARCTIC's first release is available to the public on NITRC. <http://www.nitrc.org/projects/arctic/>

Documentation has been created for the tool on the NA-MIC wiki pages, including two tutorials. The tutorials won first prize at the NA-MIC 2009 annual meeting tutorial contest. Pediatric and adult brain atlases used by ARCTIC also are available on MIDAS. <http://www.insight-journal.org/midas/collection/view/34> Although ARCTIC remains in development while we improve its integration within Slicer3, by the end of this project year, ARCTIC should be cross-platform, with Windows and MAC executables available on NITRC. Moreover ARCTIC's source code soon will be available to the community via a SVN repository.

**Local:** Local cortical thickness analysis is more complex than regional analysis. Improvement has been made on the pipeline level to accommodate for the additional steps in this mesh-based method. The main components for this pipeline include (1) tissue segmentation; (2) atlas-based ROI segmentation; (3) white matter map creation and post-processing; (4) genus-zero white matter map image and surface creation; (5) cortical thickness computation; (6) white matter mesh inflation; (7) sulcal depth computation; and (8) cortical correspondence on inflated meshes using a particle system. C++ based applications have been developed as Slicer3 external modules to perform these steps. The last step regarding the cortical correspondence module is currently being tested. We expect the whole the mesh-based local cortical thickness analysis pipeline to be fully working by the end of the current project year. Attention then will be focused on integrating this high-level module within Slicer3.

### **Clinical Component**

ARCTIC has been tested clinically on a pediatric dataset, but we plan to compare it with the state of the art application FreeSurfer. Results are available on our DPB project page. <http://wiki.na-mic.org/Wiki/index.php/DBP2:UNC> A statistical study based on Pearson's correlation thus is currently in progress using 40+ cases from FreeSurfer's publicly available tutorial dataset.

Once we have demonstrated adequate validity of the ARCTIC tool and have completed work on the local cortical thickness pipeline (described above), we plan to conduct group-based comparisons (autism vs. typical) that examine regional and local cortical thickness differences in our pediatric sample.

During the past year we have prepared a paper (in press) and have presented our methods work at IMFAR (see below).

## PAPERS AND PRESENTATIONS

### ***Peer-reviewed articles in journals***

Oguz I., Niethammer M., Cates J., Whitaker R., Fletcher T., Vachet C., and Styner M., Cortical Correspondence with Probabilistic Fiber Connectivity, Information Processing in Medical Imaging, IPMI 2009, LNCS, in press.

### ***Peer-reviewed full length articles in conference proceedings***

Cates J., Fletcher P., Styner M., Hazlett H., Whitaker R. Particle-Based Shape Analysis of Multi-object Complexes. Int Conf Med Image Comput Comput Assist Interv. 2008;11(Pt 1):477-485. PMID: 18979781.

### ***Other (abstracts, tutorials, non peer-reviewed workshop articles)***

Hazlett H.C., Vachet C., Mathieu C., Styner M., Piven J. Use of the Slicer3 Toolkit to Produce Regional Cortical Thickness Measurement of Pediatric MRI Data. Presented at the 8th Annual International Meeting for Autism Research (IMFAR) Chicago, IL 2009.

### **Additional information is available on the NA-MIC wiki**

[http://wiki.na-mic.org/Wiki/index.php/DBP2:UNC:Cortical\\_Thickness\\_Roadmap](http://wiki.na-mic.org/Wiki/index.php/DBP2:UNC:Cortical_Thickness_Roadmap)

## 2.4. Roadmap Project: Needle-Positioning Robot Integration for MR-Guided Prostate Biopsy

### Key Investigators

**Gabor Fichtinger**, PI, Queen's University

**Purang Abolmaesumi**, Co-I, Queen's University

**David Gobbi**, Software Engineer Lead: Queen's University

**Siddharth Vikal**, Software Engineer Support: Queen's University

**Katie Hayes**, NA-MIC Engineering, Brigham and Women's Hospital

**Allen Tannenbaum**, NA-MIC Algorithms, GeorgiaTech

**Host Institutions:** Queen's University & Johns Hopkins University

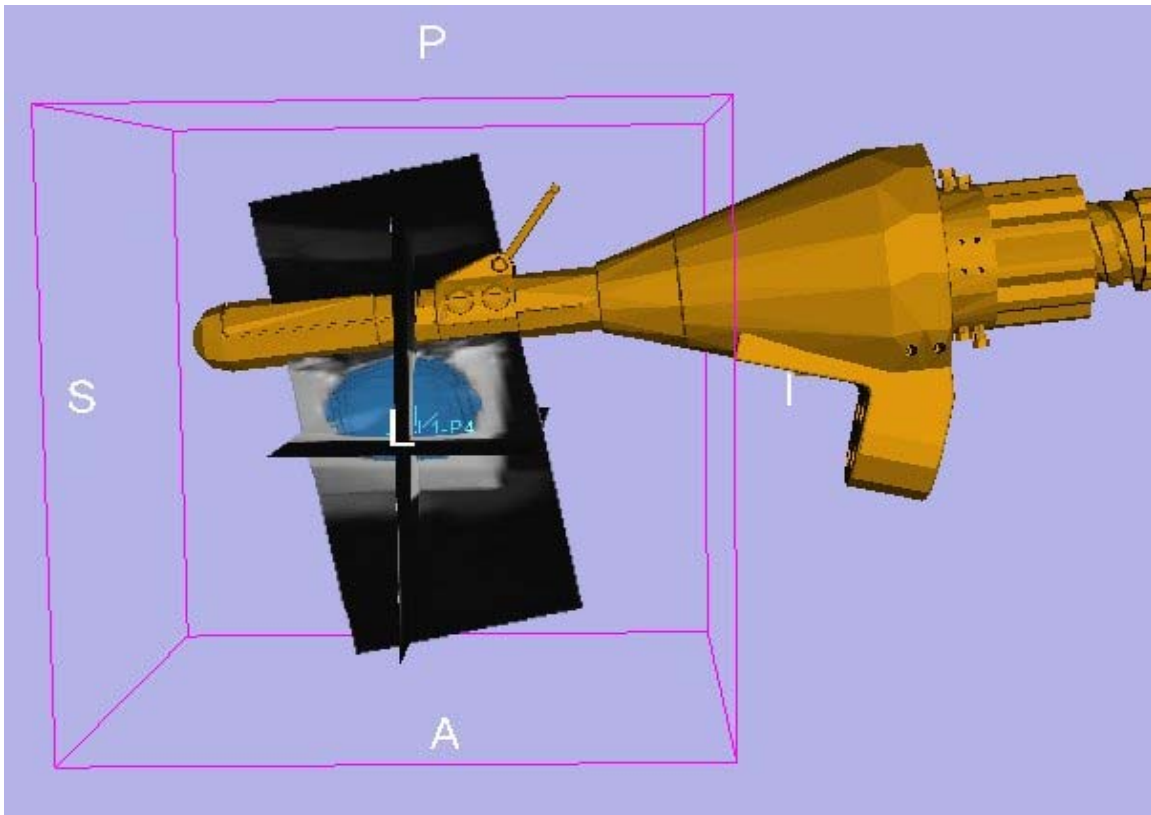

**Figure 4.** View of the transrectal prostate biopsy robot as visualized in Slicer.

### Overview

Numerous studies have demonstrated the efficacy of image-guided needle-based therapy and biopsy in the management of prostate cancer. However, the accuracy of traditional prostate interventions that rely on transrectal ultrasound (TRUS) is limited by image fidelity, needle template guides, needle deflection, and tissue deformation. Magnetic resonance imaging (MRI) is an ideal modality for guiding and monitoring such interventions because it provides excellent visualization of the prostate, as well as its sub-structure and surrounding tissues.

We have designed a comprehensive robotic assistant system that permits prostate biopsy and brachytherapy procedures to be performed entirely inside a 3T closed MRI scanner. The current system applies the transrectal approach to the prostate. With this



approach, an endorectal coil and steerable needle guide, both tuned to 3T magnets and invariably to any particular scanner, are integrated into the MRI compatible manipulator. Under the NA-MIC initiative, the interface between image computing, visualization, intervention planning, and kinematic planning is being managed by an open-source system built on the NA-MIC toolkit and its components, namely, Slicer3 and ITK. These tools are complemented by a collection of unsupervised prostate segmentation and registration methods that are important to the clinical performance of the interventional system as a whole.

### **Algorithm Component**

Our algorithms team at Georgia Tech has provided technical support for this DBP, working on both the segmentation and registration of prostate from MRI and ultrasound data. This process is described below.

**Prostate Segmentation:** The first step of this process is to "extract" the prostate. We have provided two methods: a shape-based method and a semi-automatic method. More details are given below and images and further details may be found on the NA-MIC wiki. <http://www.na-mic.org/Wiki/index.php/Projects:ProstateSegmentation>

**A shape-based algorithm:** This process begins by learning a group of shapes, which are obtained by manually segmenting a set of prostate 3D images. With the shapes represented as the hyperbolic tangent of the signed distance functions, principal component analysis (PCA) is used to learn the shapes. Then, when given a new prostate image, we search the learned shape space to find one shape that best segments the given image. The fitness of one shape to segment the image is evaluated by an energy function that measures the discrepancy of the statistical characteristics inside and outside the current segmentation boundary. This method is robust to the noise in the images. Moreover, the whole algorithm pipeline has been integrated into Slicer3 through the command line module.

**Semi-automatic method:** This method is based on a random walk segmentation algorithm. By using user-provided initial seed regions inside and outside the object (prostate), the algorithm computes a probability distribution over the image domain by solving a boundary value partial differential equation (PDE), where the value at seed regions is fixed at 1.0 or 0.0, depending on whether they represent object or background seeds. The resulting distribution indicates the probability of each voxel belonging to the object. Simply thresholding by 0.5 gives the segmentation of the object. Moreover, if the result is not suitable, the user can edit the seed regions, and the new result is computed based on this previous result. This algorithm has been integrated into the transrectal prostate MRI module of Slicer3.

**Prostate Registration:** The Georgia Tech team also has developed a nonlinear (affine) prostate registration method by treating prostate images as point sets. Then the Iterative Closest Point algorithm is improved to register the point sets generated by the two images to be registered. The proposed method shows robustness to long distance translation and partial image structure. Moreover, such representation is much sparser than sampling the image on the uniform grid. Hence, the registration is very fast compared to 3D volumetric image registration. Furthermore, the registration is viewed as a posterior estimation problem, in which the distributions of the affine and translation parameters are to be estimated. Naturally, this can be estimated using a particle filter framework. Through this, the method can handle the otherwise difficult cases where the

two prostates are viewed from different perspectives, one supine and one prone.

More details are available on the NA-MIC wiki. <http://wiki.na-mic.org/Wiki/index.php/DBP2:JHU:Roadmap>

### **Engineering Component**

An end-to-end slicer loadable module that interfaces with the MRI-compatible robotic device to perform MRI-guided prostate biopsy has been developed. A complete end-user tutorial and documentation has been uploaded on the project wiki page, together with the sample tutorial dataset (phantom) to facilitate user training. This is one of the first modules to use Slicer as an interventional tool as opposed to its traditional use as a post-processing tool.

This has been a year of ideas-to-implementation. The designs hatched by our team were realized before the end of the reporting period and the following functionality was implemented.

**GUI:** An intuitive workflow-based graphics-user interface (GUI) was conceived and implemented. This GUI clearly identifies four phases of the intervention (device calibration/registration, prostate segmentation, targeting, and verification) and guides the user through the process.

**Calibration/Registration:** The robotic device calibration/registration to scanner coordinates were achieved by means of segmenting fiducial markers in images. The registration parameters are used in targeting the steps for calculation of targeting parameters and needle trajectory. The optical encoders on the robotic device are interfaced. These sensors continuously sense the device rotation and needle angle and are sent over the USB interface. Our module reads these on a 500-msec timer event.

**Prostate Segmentation Algorithm:** The Prostate Segmentation algorithm developed by our algorithm core collaborators at Georgia Tech was integrated during the NA-MIC programming week in Salt Lake City, Utah. The details of this procedure were provided above. The targeting step enables the user to pick anatomic locations of interest by just clicking in any of 3 slice views. 3D Slicer's arbitrary reformat plane widget is an attractive feature that enables the user/clinician to visualize and pick a target in any desired plane. When a target is picked, the targeting parameters (device rotation and needle angle) necessary for the device to hit the intended target are calculated and updated in the list of targets. Multiple targets can be picked and associated with a particular type of needle (e.g., biopsy or seed). Once a particular target is selected from the list of targets, it is brought into view on all three slices and highlighted in the 3D view, and the information about the target and targeting parameters is displayed. Further, the robot's needle trajectory to the target is also visualized in 3D; this provides crucial feedback for the clinician.

The biopsy is performed, and a validation volume is acquired while the needle is still in the prostate; this validation volume then is used to perform validation analysis, to determine the accuracy with which the device hit the target.

Throughout the year, we have sought and received timely help from the Engineering Core. In several instances, some functionality in Slicer was implemented for our specific requirements. The current engineering efforts are focused on testing the module at



various levels, as well as detecting and fixing bugs. We are in the process of designing a test protocol for functional and clinical evaluation of the software. Efforts also are being made to add more functionality, including (1) additional dedicated MR room display window, which will display the chosen 2D image view for a particular target, the required robot targeting parameters, and the sensed robot parameters; (2) an option to load the previously saved experiment for post-op analysis; (3) and an option to visualize robot anatomical coverage at the calibration step, itself, which can be used to reposition the device if necessary.

### **Clinical Component**

Since last year, the robotic hardware has undergone major re-design and re-engineering. We have completed detailed hardware safety tests and inaugurated the device for clinical use. Just recently, we treated the first batch of patients. For the sake of clinical safety, we opted not to upgrade the interface software for this initial round of patients. In the meantime, all new image processing and visualization functions have been implemented in the 3D Slicer interface alone, and we no longer have to retrofit older existing software with major new features. The Slicer 3D-based target planning and device control interface will be inaugurated gradually during the project year.

**Additional information is available on the NA-MIC wiki**  
<http://wiki.na-mic.org/Wiki/index.php/DBP2:JHU:Roadmap>

### 3. FOUR INFRASTRUCTURE TOPICS

#### 3.1 Diffusion Image Analysis

##### Key Investigators

**BWH:** Marek Kubicki, Martha Shenton, Sylvain Bouix, Julien von Siebenthal, Thomas Whitford, Jennifer Fitzsimmons, Doug Terry, Jorge Alverado, Eric Melonakos, Alexandra Golby, Monica Lemmond, Carl-Fredrik Westin.

**MIT:** Lauren O'Donnell, Polina Golland, Tri Ngo

**Utah I:** Tom Fletcher, Ross Whitaker, Ran Tao, Yongsheng Pan

**Utah II:** Casey Goodlett, Sylvain Gouttard, Guido Gerig

**GA Tech:** John Melonakos, Vandana Mohan, Shawn Lankton, Allen Tannenbaum

**GE:** Xiaodong Tao, Jim Miller, Mahnaz Maddah

**Isomics:** Steve Pieper

**Kitware:** Luis Ibanez, Brad Davis

**UNC:** Zhexing Liu, Martin Styner

##### Summary of Progress

Significant progress was made in refining tools for diffusion-weighted imaging (DWI) and applying existing implementations to clinical studies. This progress is best documented in the 14 new papers related to diffusion tensor imaging (DTI) published since the previous year's report, with 11 appearing in high-impact journals [Neuroimage (3), IEEE TMI (2), MEDIA (2), MRM (1), Schizophr Res (3)], 2 appearing in peer-reviewed conference proceedings [(MICCAI (2))], and 1 other at a scientific workshop. These publications are excellent indicators not only that NA-MIC tools and methodologies are competitive and being recognized by highly respected medical image analysis journals, but also that the application of these tools and methodologies to clinical studies, including validation and testing, is competitive and being recognized by clinically oriented journals. The scale of these methods can be characterized as both small, such as the processing of DWI to extract fiber bundles of interest in particular patients and large, such as the population-based analysis of DWI for group comparison and hypothesis testing. Significant progress in both categories is reported.

Core 1 partners contributed to the development of methods for image preprocessing, such as filtering and artifact removal, by providing improved tractography algorithms, methods for clustering of streamlines into meaningful tracts, group-wise analysis via computational anatomy tools, and methods for quantitative analysis of tracts to provide parameters for statistical analysis. Core 2 contributed significantly not only by providing the computational environment for user-guided, interactive DTI analysis which relies on a complex user interface and sophisticated visualization, but also by developing plug-in capabilities for more automated processing modules. Core 3 made increasing use of these tools to analyze data from clinical studies, and there was significant handshaking amongst the engineers of the Core 3 partners, the methods developers of Core 1, and the engineers of Core 2. Core 5 organized several training courses, including DTI analysis, where participants could learn about the underlying imaging and image analysis concepts and the use of the Slicer software environment.

The following list summarizes the major new contributions to Diffusion Image Analysis during the present reporting period.

## Major Developments in Diffusion Image Analysis

**Fiber Tract Modeling, Clustering, and Quantitative Analysis (MIT):** Ongoing development of population-based analysis of DTI via clustering of fiber tracts for automatic labeling has continued and resulted in a recent journal publication (O'Donnell L, *Neuroimage* 2009). As a new research direction, the group approached the challenging problem of joint registration and segmentation of DWI fiber tractography, where tract labels are assigned in an iterative framework by registration of bundles to an atlas. This results in the nonlinear joint registration of sets of DWI data into a common coordinate space, and at the same time, automatic labeling of joint tracts. Quantitative analysis in population studies is based upon correspondence obtained via clustering and labeling.

**Stochastic Tractography (MIT, DBP 2):** Stochastic Tractography was a major research effort of this group during the reporting period. Initial prototype software was integrated into Slicer 3, which brought significant challenges with regard to user interaction, visualization, and definition of data structures for subsequent statistical analysis. The advantages of Stochastic Tractography are clearly shown in areas of crossing fibers, uncertainties, considerable noise – all situations where conventional Deterministic Tractography methods would fail. Two journal papers explored the potential advantages of using the orientation distribution function from DWI rather than the simplified tensor model (Rathi, *Media* 2009; Aja-Fernandez, *TMI* 2008). This project is a joint collaboration between Core 1, Core 2, and Core 3, and nicely demonstrates the close interaction between methods development, engineering, and testing and validation in a clinical environment. Four journal publications (Kawashima, Lee, Fitzsimmons, Kubicki, *Schizophr Res*) show application of these novel analysis tools to clinical studies.

**Geodesic Tractography Segmentation (Georgia Tech):** As an alternative to Streamline Tractography, this project develops a technique for extraction of a minimum cost curve through the tensor field, resulting in an anchor curve between source and target regions specified by the user (Niethammer, *Neuroimage* 2009). As an extension, Volumetric Fiber Segmentation based on active contours but using the anchor curves as initialization has been developed. This led to a framework for Tubular Surface Segmentations, which was presented at a conference workshop (Mohan, *MFCA* 2008).

**DTI Processing and Statistical Tools (Utah 1):** This research addresses the important problem of correcting artifacts of DWI. Image distortions due to eddy currents in gradient directions and susceptibility artifacts of echoplanar imaging (EPI) acquisition are corrected via a combined scheme of aligning individual gradient images and calculating a nonlinear transformation between DWIs and a geometrically correct T2-weighted image. The whole pipeline is written in ITK and is tested on a larger number of datasets. The methodology is in print and will be presented at a peer-reviewed conference (*IPMI* 2009). This group also continued further development of the volumetric white matter connectivity tool, i.e., a method dual to tractography that optimizes a shortest path through the tensor field.

**Population-Based Analysis of White Matter Tracts (Utah 2):** The population-based analysis system starts with DWI from a large set of subjects and yields a statistical analysis of selected fiber tracts. More information about this project is available on the NA-MIC wiki. [http://www.na-mic.org/Wiki/index.php/ Projects](http://www.na-mic.org/Wiki/index.php/Projects):

**DTIPopulationAnalysis** The steps involved in this system include (1) calculation of image features; (2) linear and nonlinear registration into a common, unbiased coordinate system; (3) user-guided selection of tracts of interests in atlas-space; (4) mapping tract geometry back into individual images to collect subject-specific diffusion information; and (5) statistical group analysis of tract diffusion information. New activities in this reporting period include the use of a Core 1 developed methodology for group-wise registration of population of images (in collaboration with MIT). <http://www.na-mic.org/Wiki/index.php/Projects:GroupwiseRegistration> Core 1 also developed a statistical framework for tract analysis based on functional data analysis (FDA). The new methods are described in a conference and a journal publication (Goodlett et al., *Neuroimage* 2009, *MICCAI* 2008). The whole system was applied to large studies of our Core 3 partner (PNL Harvard) and pediatric studies from our affiliated clinical partners at UNC. As an attempt to combine this framework with Stochastic Tractography, we have developed an efficient algorithm with a novel sampling strategy (Fan et al., *Media* 2009).

**DTI Tractography Based on Navier-Stokes (UCLA):** The UCLA group developed a new tractography that makes use of the Navier-Stokes method rather than conventional PDE for tracking (Hagemann, *TMI* 2009).

The sum of these activities by all partners includes the whole processing pipeline from data input via NRRD format; preprocessing and correction for artifacts and distortions; several choices for tractography tailored to different needs; and output of results for statistical analysis. A summary of the most recent progress of DTI tool development based on the point of view of the DBP 2 partner (Harvard) is available on the NA-MIC wiki, with links to all current activities. <http://www.na-mic.org/Wiki/index.php/DBP2:Harvard>

**Additional Information is available at the following links:**

**Summary of internal collaborations** [http://wiki.na-mic.org/Wiki/index.php/NA-MIC\\_Internal\\_Collaborations:DiffusionImageAnalysis](http://wiki.na-mic.org/Wiki/index.php/NA-MIC_Internal_Collaborations:DiffusionImageAnalysis)

**Detailed methods and algorithms for DWI analysis can be found in the algorithm sections of the respective Core-1 partners** <http://www.na-mic.org/Wiki/index.php/Algorithm:Main>

**DBP-2 project descriptions** <http://www.na-mic.org/Wiki/index.php/DBP2:Main>

**External and internal NAMIC collaboration pages**  
[http://www.na-mic.org/Wiki/index.php/NA-MIC\\_Collaborations:New](http://www.na-mic.org/Wiki/index.php/NA-MIC_Collaborations:New)

## PAPERS AND PRESENTATIONS

### *Peer-reviewed articles in journals*

Rathi Y., Michailovich O., Shenton M.E., Bouix S. Directional functions for orientation distribution estimation. *Med Image Anal.* 2009 Jun;13(3):432-44. PMID: 19269242.  
Kawashima T., Nakamura M., Bouix S., Kubicki M., Salisbury D., Westin C., McCarley R., Shenton M. Uncinate fasciculus abnormalities in recent onset schizophrenia and

affective psychosis: A diffusion tensor imaging study. *Schizophr Res.* 2009 May;110(1-3):119-126. PMID: 19328656.

O'Donnell L., Westin C., Golby A.J. Tract-based morphometry for white matter group analysis. *Neuroimage.* 2009 Apr 15;45(3):832-44. PMID: 19154790.

Niethammer M., Zach C. Melonakos J., Tannenbaum A. Near-tubular fiber bundle segmentation for diffusion weighted imaging: segmentation through frame reorientation. *Neuroimage.* 2009 Mar;45(1 Suppl):S123-32. PMID: 19101640.

Lee K., Yoshida T., Kubicki M., Bouix S., Westin C., Kindlmann G., Niznikiewicz M., Cohen A., McCarley R., Shenton M. Increased diffusivity in superior temporal gyrus in patients with schizophrenia: A Diffusion Tensor Imaging study. *Schizophr Res.* 2009 Mar;108(1-3):33-40. PMID: 19135872.

Hageman N.S., Toga A.W., Narr K.L., Shattuck D.W. A diffusion tensor imaging tractography algorithm based on Navier-Stokes fluid mechanics. *IEEE Trans Med Imaging.* 2009 Mar;28(3):348-60. PMID: 19244007.

Goodlett C., Fletcher P.T., Gilmore J.H., Gerig G. Group analysis of DTI fiber tract statistics with application to neurodevelopment. *Neuroimage.* 2009 Mar;45(1 Suppl):S133-42. PMID: 19059345.

Zhang F., Hancock E.R., Goodlett C., Gerig G. Probabilistic white matter fiber tracking using particle filtering and von Mises-Fisher sampling. *Med Image Anal.* 2009 Feb;13(1):5-18. PMID: 18602332.

Fitzsimmons J., Kubicki M., Smith K., Bushell G., San José Estepar R., Westin C., Nestor P., Niznikiewicz M., Kikinis R., McCarley R., Shenton M. Diffusion tractography of the fornix in schizophrenia. *Schizophr Res* 2009 Jan; 107:39–46. PMID: 19046624.

Kubicki M., Styner M., Bouix S., Gerig G., Markant D., Smith K., Kikinis R., McCarley R.W., Shenton M.E. Reduced interhemispheric connectivity in schizophrenia-tractography based segmentation of the corpus callosum. *Schizophr Res.* 2008 Dec;106(2-3):125-31. PMID: 18829262.

Khachaturian M.H., Arsenault J., Ekstrom L.B., Tuch D.S., Vanduffel W. Focal reversible deactivation of cerebral metabolism affects water diffusion. *Magn Reson Med.* 2008 Nov;60(5):1178-89. PMID: 18958855.

Aja-Fernandez S., Niethammer M., Kubicki M., Shenton M.E., Westin C. Restoration of DWI data using a Rician LMMSE estimator. *IEEE Trans Med Imaging.* 2008 Oct;27(10):1389-403. PMID: 18815091.

***Peer-reviewed full length articles in conference proceedings***

Ziyan U., Westin C. Joint Segmentation of Thalamic Nuclei from a Population of Diffusion Tensor MR Images. *Int Conf Med Image Comput Comput Assist Interv.* 2008;11(Pt 1):279-286. PMID: 18979758.

Goodlett C., Fletcher P.T., Gilmore J.H., Gerig G. Group Statistics of DTI Fiber Bundles Using Spatial Functions of Tensor Measures. *Int Conf Med Image Comput Comput Assist Interv.* 2008;11(Pt1):1068-1075. PMID: 18979851.

***Others (abstracts, tutorials, non peer-reviewed workshop articles)***

Mohan V., Sundaramoorthi G., Melonakos J. Niethammer M., Kubicki M., Tannenbaum A. Tubular Surface Evolution for Segmentation of the Cingulum Bundle From DW-MRI. *Proceedings of the Second Workshop on Mathematical Foundations of Computational Anatomy (MFCA'08), Int Conf Med Image Comput Comput Assist Interv.* 2008.

***Presentations related to DTI Analysis***

- Goodlett, Casey, *Improved Correspondence for DTI Population Studies via Unbiased Atlas Building*, ISMRM Educational Course on Diffusion MRI Software, April 2009
- Gerig, Guido, Invited panel presentation: White Matter Development in Very Early Ages: Normative Models of Healthy Growth to study Risk Populations and Disease, ACNP 2008, Scottsdale, AZ, Dec. 10, 2008
- Gerig, Guido, Mapping Early Brain Development via Neuroimaging, invited presentation UCLA LONI CCB Seminar, Los Angeles, CA Nov. 7, 2008,
- Gerig, Guido, Computational pipelines for clinical studies, invited talk for Tutorial on DTI, MICCAI 2008, NYU, New York Sept. 6, 2008
- Gerig, Guido, Analysis of brain white matter properties via DW MRI: The role of normative atlases, invited presentation at 5<sup>th</sup> Annual World Congress of IBMISPS (Int. Brain Mapping and Intraoperative Surgical Planning Society), Los Angeles, CA August 28. 2008,

## 3.2 Structural Analysis

### Key Investigators

**MIT:** Polina Golland, Kilian Pohl, Sandy Wells, Eric Grimson, Mert R. Sabuncu

**UNC:** Martin Styner, Ipek Oguz, Nicolas Augier, Marc Niethammer, Beatriz Paniagua

**Utah:** Ross Whitaker, Guido Gerig, Suyash Awate, Tolga Tasdizen, Tom Fletcher, Joshua Cates, Miriah Meyer

**GaTech:** Allen Tannenbaum, John Melonakos, Vandana Mohan, Tauseef ur Rehman, Shawn Lankton, Samuel Dambreville, Yi Gao, Romeil Sandhu, Xavier Le Faucheur, James Malcolm, Ivan Kolosev

**Isomics:** Steve Pieper

**GE:** Jim Miller

**Kitware:** Luis Ibanez, Karthik Krishnan

**UCLA:** Arthur Toga, Michael J. Pan, Jagadeeswaran Rajendiran

**BWH:** Sylvain Bouix, Motoaki Nakamura, Min-Seong Koo, Martha Shenton, Marc Niethammer, Jim Levitt, Yogesh Rathi, Marek Kubicki, Steven Haker

### Summary of Progress

Under Structural Analysis, the main topics of research for NA-MIC are structural segmentation, registration techniques, and shape analysis. These topics are interrelated and hence research in one often finds application in another. For example, shape analysis can yield useful priors for segmentation, or segmentation and registration can provide structural correspondences for use in shape analysis and so on. An overview of selected progress highlights under these broad topics follows.

### Segmentation

**Geodesic Tractography Segmentation:** We have proposed an image segmentation technique based on augmenting the conformal (or geodesic) active contour framework with directional information. This has been applied successfully to the segmentation of neural fiber bundles such as the cingulum bundle. This framework now has been integrated into Slicer and is being tested on a population of brain datasets.

**Tubular Surface Segmentation:** We have proposed a new model for tubular surfaces that transforms the problem of detecting a surface in 3D space, to detecting a curve in 4D space. Besides allowing us to impose a "soft" tubular shape prior, this model also leads to computational efficiency over conventional surface segmentation approaches. We also have developed the moving end points implementation of this framework, wherein the required input is only a few points in the interior of the structure of interest. This yields the additional advantage that the framework simultaneously returns both the 3D segmentation and the 3D skeleton of the structure, thus eliminating the need for *a priori* knowledge of end points, and an expensive skeletonization step. The framework is applicable to different tubular anatomical structures in the body. We have so far applied it successfully to the cingulum bundle and blood vessels.

**Local-Global Segmentation:** We have proposed a novel segmentation approach that combines the advantages of local and global approaches to segmentation, by using statistics over regions that are local to each point on the evolving contour. This approach is well suited to applications with contrast differences within the structure of interest, such as in blood vessel segmentation. It is also suited to

applications such as the neural fiber bundles, where the diffusion profiles of voxels within the structure are locally similar but vary along the length of the fiber bundle itself.

**Shape-Based Segmentation:** Standard image-based segmentation approaches perform poorly when there is little or no contrast along boundaries of different regions. In such cases, segmentation is mostly performed manually by using prior knowledge of the shape and relative location of the underlying structures combined with partially discernible boundaries. We have presented an automated approach guided by covariant shape deformations of neighboring structures, which is an additional source of prior knowledge. Captured by a shape atlas, these deformations are transformed into a statistical model by using the logistic function. The mapping between atlas and image space, structure boundaries, anatomical labels, and image inhomogeneities is estimated simultaneously within an Expectation-Maximization formulation of the Maximum A posteriori Probability (MAP) estimation problem. These results then are fed into an Active Mean Field approach, which views the results as priors to a Mean Field approximation with a curve length prior. We have applied the algorithm successfully to real MRI images, and we also have implemented it into 3D Slicer.

**Re-Orientation Approach for Segmentation of DW-MRI:** This work proposes a methodology to segment tubular fiber bundles from diffusion weighted magnetic resonance images (DW-MRI). Segmentation is simplified by locally reorienting diffusion information based on large-scale fiber bundle geometry. Segmentation is achieved through simple global statistical modeling of diffusion orientation, which permits convex optimization formulation of the segmentation problem, combining orientation statistics and spatial regularization. The approach compares very favorably with segmentation by full-brain streamline tractography.

## Registration

**Optimal Mass Transport-based Registration:** We have provided a computationally efficient non-rigid/elastic image registration algorithm based on the Optimal Mass Transport theory. We use the Monge-Kantorovich formulation of the Optimal Mass Transport problem and implement the solution proposed by Haker et al. using multi-resolution and multigrid techniques to speed up the convergence. We also leverage the computation power of general-purpose graphics processing units available on standard desktop computing machines to exploit the inherent parallelism in our algorithm. We extend the work by Haker et al. who computed the optimal warp from a first order partial differential equation (PDE), an improvement over earlier proposed higher order methods and those based on linear programming. We further implement the algorithm by using a coarse-to-fine strategy, which results in phenomenal improvement in convergence. We have applied it successfully to the registration of 3D brain MRI datasets (preoperative and intra-operative), and are currently extending it to the non-rigid registration of baseline DWI to brain MRI data.

**Atlas Regularization for Image Segmentation:** Atlas-based approaches have demonstrated the ability to automatically identify detailed brain structures from 3-D magnetic resonance (MR) brain images. Unfortunately, the accuracy of this type of method often degrades when processing data acquired on a different scanner platform or pulse sequence in comparison with the data used for the atlas training. In this paper, we improve the performance of an atlas-based whole brain segmentation method by introducing an intensity renormalization procedure that automatically adjusts the prior



atlas intensity model to new input data. Validation with manually labeled test datasets has shown that the new procedure improves the segmentation accuracy (as measured by the Dice coefficient) by 10% or more for several structures including hippocampus, amygdala, caudate, and pallidum. The results verify that this new procedure reduces the sensitivity of the whole brain segmentation method to changes in scanner platforms and improves its accuracy and robustness, which thus facilitates multicenter or multisite neuroanatomical imaging studies.

**Point-Set Rigid Registration:** We have proposed a particle-filtering scheme for the registration of 2D and 3D point sets undergoing a rigid body transformation. Moreover, we incorporate stochastic dynamics to model the uncertainty of the registration process. We treat motion as a local variation in the pose parameters obtained from running a few iterations of the standard Iterative Closest Point (ICP) algorithm. Using this idea, we introduced stochastic motion dynamics to widen the narrow band of convergence as well as provide a dynamic model of uncertainty. In contrast with other techniques, our approach requires no annealing schedule, which reduces the computational complexity and maintains the temporal coherency of the state (i.e., no loss of information). Also, unlike most alternative approaches for point set registration, we make no geometric assumptions on the two datasets. We applied the algorithm to different alignments of point clouds and it successfully found the correct optimal transformation that aligns two given point clouds, despite the differing geometry around the local neighborhood of a point within their respective sets.

**Regularization for Optimal Mass Transport:** To extend the flexibility of the existing Optimal Mass Transport algorithm, we added a regularization term to the function being minimized. This term controls the tradeoff between how well two images match after registration versus how warped the transformation map can become. A weighted sum of squared differences is used to penalize having to move mass over long distances; this addition also helps to keep the transformation physically accurate by reducing the likelihood that the transformation grid will fold over itself and keeping the grid smooth.

**Registration of DW-MRI to Structural MRI:** Optimal Mass Transport was applied to the problem of correcting EPI distortion in DW-MRI. A mask for white matter in DW-MRI was registered to the white matter mask extracted from the structural MRI for the same patient. Prior to registration, it is important to normalize intensities in the two masks; this was done by dividing the images into regions and uniformly normalizing over each region to assure the sum of the intensities is equal. Then, once a transformation between the white matter masks was calculated, this transformation was applied to the original DW-MRI image.

## Shape Analysis

**Shape Analysis Framework Using SPHARM-PDM:** We have provided an analysis framework of objects with spherical topology, described by sampled spherical harmonics SPHARM-PDM. The input is a set of binary segmentations of a single brain structure, such as the hippocampus or caudate. These segmentations are first processed to fill any interior holes. The processed binary segmentations are converted to surface meshes, and a spherical parametrization is computed for the surface meshes using area preserving, distortion minimizing spherical mapping. The SPHARM description is computed from the mesh and its spherical parametrization. By using the

first order ellipsoid from the spherical harmonic coefficients, the spherical parametrizations are aligned to establish correspondence across all surfaces. The SPHARM description then is sampled into triangulated surfaces (SPHARM-PDM) via icosahedron subdivision of the spherical parametrization. These SPHARM-PDM surfaces are all spatially aligned using rigid Procrustes alignment. Group differences between groups of surfaces are computed for simple group wise comparison using the standard robust Hotelling T 2 sample metric. This tool further provides a new statistical method that allows one to test and control with subject covariates via a permutation testing of GLM-based MANCOVA metrics. Statistical p-values, both raw and corrected for multiple comparisons, result in significance maps. We provide additional visualization of the group tests via mean difference magnitude and vector maps, maps of the group covariance information, local correlation, and z-scores. We have a stable implementation, and current development focuses on integrating the current command line tools into Slicer via the Slicer execution model and XNAT integration. A first Slicer module prototype has been developed without XNAT integration.

**Population Studies Using Tubular Surface Model:** We have proposed a tubular shape model for the cingulum bundle which models a tubular surface as a center-line coupled with a radius function at every point along the center-line. This model shows potential for population studies on the cingulum bundle, which is believed to be involved in schizophrenia, since it provides a natural way of sampling the structure to build a feature representation of it. We are currently segmenting the cingulum bundle from a population of brain datasets, towards performing this population analysis using the Pott's Model.

**Automatic Outlining of Sulci on a Brain Surface:** We present a method to automatically extract certain key features on a surface. We apply this technique to outline sulci on the cortical surface of a brain, where the data is taken to be a 3D triangulated mesh formed from the segmentation of MR image slices. The problem is posed as energy minimization by penalizing the arc-length of segmenting curve using conformal factor involving the mean curvature of the underlying surface. The computation is made practical for dense meshes via the use of a sparse-field method to track the level set interfaces and regularized least-squares estimation of geometric quantities.

**Additional information is available on the NAMIC wiki.**

[http://wiki.na-mic.org/Wiki/index.php/NA-MIC\\_Internal\\_Collaborations:StructuralImageAnalysis](http://wiki.na-mic.org/Wiki/index.php/NA-MIC_Internal_Collaborations:StructuralImageAnalysis)

### 3.3 fMRI Analysis

#### Key Investigators

**MIT:** Polina Golland, Danial Lashkari, Archana Venkataraman, Clare Poynton

**Harvard/BWH:** Sylvain Bouix, Marek Kubicki, Carl Frederick Westin, Sandy Wells

#### Summary of Progress

Our group provides support to NA-MIC for problems that involve the statistical variability of anatomy and function across subjects and between populations. We use computational models of such variability to improve predictions for individual subjects and to characterize populations. We work primarily with anatomical, DTI, and fMRI images. In the current reporting cycle, our efforts have been focused on two new methods in fMRI: one that characterizes functional connectivity patterns from fMRI, and a second that corrects the distortion present in EPI for registration with structural MRI.

**Connectivity Analysis:** One of the major goals in analysis of fMRI data is the detection of functionally homogeneous networks in the brain. We have developed a new method for characterizing functional connectivity patterns from fMRI. In contrast to the seed-based analysis typically used to identify networks of co-activation, we propose to use clustering to simultaneously estimate the networks and their representative time courses, which effectively replaces user-specified seeds. During this year, we validated this method for characterizing functional connectivity patterns from fMRI. To investigate the sensitivity of the analysis to the generative model of the signal, we implemented and compared two distinct algorithms, Mixture-Model Clustering and Spectral Clustering, in application to this problem. We validated our approach in rest state fMRI scans of 45 healthy subjects. Our results demonstrate that the detected networks are stable across subjects and across methods. At the same time, we worked with the Harvard DBP to identify relevant clinical datasets, in which our approach promises to identify the effect of a disorder. We have started a collaboration to apply the method to a group of schizophrenia patients and normal controls.

**Distortion Correction for EPI-Based Functional Imaging:** We developed and demonstrated a method that corrects the distortions present in echo planar images (EPI) and registers the EPI image to structural MRI scans. Our approach does not require acquisition of fieldmaps, modification of EPI acquisition parameters, or detailed knowledge of the shim system. The technique consists of two steps. First, a classifier is used to segment structural MR into an air/tissue susceptibility model. The resulting tissue map serves as input to a first order perturbation field model to compute a subject-specific fieldmap. The classifier is trained based on MR-CT image pairs, by using MR intensities as features and exploiting air segmentation in the CT images to construct labels. Second, a simultaneous shim estimation and registration algorithm is used to solve for the lower order field perturbations (shim parameters) needed to accurately unwarped and register the EPI data.

**Additional information is available on the NA-MIC wiki**

[http://wiki.na-mic.org/Wiki/index.php/NA-MIC\\_Internal\\_Collaborations:fMRIAnalysis](http://wiki.na-mic.org/Wiki/index.php/NA-MIC_Internal_Collaborations:fMRIAnalysis)

### 3.4 NA-MIC Kit Theme

The NA-MIC Engineering Core has, to a great extent, realized its goal of engaging the wider biomedical community. This community extends worldwide and has leveraged the efforts of many developers beyond the direct influence of NA-MIC. This has resulted in significant advances at relatively low cost. This said, and without diminishing the contributions of our many external collaborators, the senior members of the Core 2 team are:

#### Key Investigators

**Kitware:** Will Schroeder (Core 2 PI), Sebastien Barre, Luis Ibanez, Bill Hoffman

**GE:** Jim Miller, Xiaodong Tao

**Isomics:** Steve Pieper, Alex Yarmarkovich, Curt Lisle, Terry Lorber

**WUSTL:** Dan Marcus

**UCSD:** Jeffrey Grethe

#### Summary of Progress

The NA-MIC-Kit consists of a framework of advanced computational resources including libraries, toolkits, and applications; as well as the support infrastructure for testing, documenting, and deploying leading-edge medical imaging algorithms and software tools. The framework has been carefully constructed to provide low-level access to libraries and modules for advanced users, plus high-level application access that non-computer professionals can use to address a variety of problems in biomedical computing.

The focus of projects in the fifth year of the NA-MIC has been on integration. Much of the foundational infrastructure has been established; however, to effectively transition advanced biomedical technology and improve software usability, the various subsystems that compose the NA-MIC-Kit have been extended to accommodate advanced algorithmic development and optimize work flow. The activities in this year's efforts can be broadly categorized as follows:

<b>Slicer3 and the Software Framework</b>
<b>Data integration</b>
<b>Software process</b>
<b>Software releases</b>

#### Slicer3 and the Software Framework

One of the major achievements of the past year has been the release of version 3.4 of 3D Slicer in May of 2009. <http://www.slicer.org/slicerWiki/index.php/Documentation-3.4> Numerous important improvements have been made by the Engineering Core and significant new functionality has been added through other NA-MIC cores and collaborators since the release of version 3.2 in August of 2008. A few notable examples include:

- **An Integrated Data Save Dialog**  
<http://www.slicer.org/slicerWiki/index.php/Modules:Saving-Documentation-3.4>
- **Significant Rework of the Fiducials Interface**  
<http://www.slicer.org/slicerWiki/index.php/Modules:Fiducials-Documentation-3.4>
- **A Slices Module to Support Advanced Visualization Modes**  
<http://www.slicer.org/slicerWiki/index.php/Modules:Slices-Documentation-3.4>
- **Significant Improvements to the Interactive Label Map Editor**  
<http://www.slicer.org/slicerWiki/index.php/Modules:Editor-Documentation>
- **Integration of a Brain Tumor Change Tracking Module in collaboration with the Brain Science Foundation**  
<http://www.slicer.org/slicerWiki/index.php/Modules:ChangeTracker-Documentation-3.4>
- **Integration of a Finite Element Meshing Module as a deliverable of the NA-MIC Collaboration Grant at the University of Iowa**  
[http://www.slicer.org/slicerWiki/index.php/Modules:IA\\_FEMesh-Documentation-3.4](http://www.slicer.org/slicerWiki/index.php/Modules:IA_FEMesh-Documentation-3.4)
- **A Medical Informatics Interface to XNAT in collaboration with BIRN**  
<http://www.slicer.org/slicerWiki/index.php/Modules:FetchMI-Documentation-3.4>
- **The Ability to Interactively Script Slicer in Python as well as Tcl**  
<http://www.slicer.org/slicerWiki/index.php/Slicer3:Python>

In addition, there have been major extensions to the diffusion imaging tools, registration tools, filters, image-guided therapy, and other core changes that enhance the utility and applicability of the software.

### **Data Integration**

One of the keys to effective workflow is integration of computational tools with data. To this end, XNAT and BatchMake are directly accessible from Slicer3. XNAT, or the eXtensible Neuroimaging Archive Toolkit, is an open source software platform designed to facilitate management and exploration of neuroimaging and related data. XNAT database can now be directly accessed through the Slicer3 file menu with additional support for data upload and query. BatchMake is a simple, scriptable, cross-platform batch-processing tool that now interfaces to XNAT and can be launched from the Slicer3 application. This means that users can interactively configure computational experiments to process data from an XNAT data repository and then process potentially large collections of data, either locally or distributed across the grid by using Condor.

### **Software Process**

One of the challenges facing developers has been the requirement to implement, test, and deploy software systems across multiple computing platforms. NA-MIC continues to push the state of the art with further development of the CMake, CTest/CDash, CPack, and tools for cross-platform development, testing, and packaging, respectively. In particular, this year saw significant advances in the development of the PHP-based CDash server, which now provides sophisticated query/retrieve, notification, and testing-

results navigation. The CMake system continues to grow rapidly both in the NA-MIC community as well as external to it, reaching a level of approximately 1,000 downloads per day in early 2009 (this figure does not include the CMake distributions now embedded in Linux distributions such as Debian Linux). Other important additions this year include better support for integration of execution modules into Slicer3, packaging of Slicer3 distributions for more platforms with CPack, and the introduction of GUI (Graphical User Interface) testing with the Squish tool.

**Software Releases**

The NA-MIC-Kit can be represented as a pyramid of capabilities, with the base consisting of toolkits and libraries, and the apex standing in for the Slicer3 user application. In between, Slicer modules are stand-alone executables that can be integrated directly into the Slicer3 application, including GUI integration, while workflows are groups of modules that are integrated together to manifest sophisticated segmentation, registration, and biomedical computing algorithms. In a coordinated NA-MIC effort, major releases of these many components were realized over the past year. These include, but are not limited to:

<b>Slicer 3.4</b>
<b>VTK 5.4</b>
<b>ITK 3.8, 3.10, 3.12</b>
<b>CMake versions 2.6.1 through 2.6.4</b>
<b>CDash version 1.4</b>
<b>BatchMake 1.0.6</b>

**Additional information is available on the NA-MIC wiki**  
<http://wiki.na-mic.org/Wiki/index.php/NA-MIC-Kit>

## 4. HIGHLIGHTS

NA-MIC is organized to address important clinical problems, develop new techniques to address these problems, and engineer solutions for rapid dissemination into clinical research and eventual practice. While the directly funded NA-MIC community is modest in extent, the wider NA-MIC community encompasses hundreds of researchers located around the world. This is a direct result of NA-MIC's commitment to Free and Open Source Software and open data. The following are a few important activities that have occurred over the past year.

### 4.1 Advanced Algorithms

Significant progress on developing new computational processes and algorithms is proceeding. Examples include:

- A Slicer3 module for performing individual regional cortical thickness analysis was completed this past year: ARCTIC (Automatic Regional Cortical THICKness).
- A Slicer loadable module that interfaces with an MRI-compatible robotic device to perform MRI-guided prostate biopsy was developed.
- The velocardio-facial syndrome (VCFS) Stochastic Tractography roadmap project has added several pre- and postprocessing steps to the algorithm pipeline, including Eddy Current and Geometric Distortion correction methods and DTI Filtering. Also, new methods for visualizing and quantifying Stochastic Tractography output, including the creation of connection probability distribution maps, have been developed.
- Significant progress was realized towards refining the DWI tools and applying existing implementations to clinical studies, documented in 16 publications since last year's report. Advances were seen in Fiber Tract Modeling, Clustering and Quantitative Analysis; Stochastic Tractography; Geodesic Tractography Segmentation; DTI processing and statistical tools; and Population-based analysis of white matter tracts.
- Another area of productive work was in Structural Analysis. Some of the advances include the development of new models for tubular surface segmentation, which transforms the problem of detecting a surface in 3D to detecting a curve in 4D. Another novel local-global segmentation approach was developed that combines the advantages of local and global approaches to segmentation, by using statistics over regions that are local to each point on an evolving contour.
- Development of a new method for characterizing functional connectivity patterns from fMRI based on a clustering approach.

NAMIC work continues to be published in well-regarded journals and venues. A small but typical example of the 52 papers and presentations (see Appendix A: Publications) resulting from this year's reporting period include two papers published by the journal *Schizophrenia Research*.

Levitt J., Styner M., Niethammer M., Bouix S., Koo M., Voglmaier M., Dickey C., Niznikiewicz M., Kikinis R. McCarley R., Shenton M. Shape abnormalities of caudate nucleus in schizotypal personality disorder. *Schizophr Res.* 2009 May;110(1-3):127-139. PMID: 19328654.

Kubicki M., Styner M., Bouix S., Gerig G., Markant D., Smith K. Kikinis R. McCarley R.W., Shenton M.E. Reduced interhemispheric connectivity in schizophrenia-tractography based segmentation of the corpus callosum. *Schizophr Res.* 2008 Dec;106(2-3):125-31. PMID: 18829262.

Dissemination of technical content is an on-going activity of NA-MIC. For example, we have realized over 1500 downloads of a single paper from our Publication Database repository (Using the logarithm of odds to define a vector space on probabilistic atlases, Kilian Pohl et al.). The Publication Database contains 228 NAMIC-related publications, many of which have been downloaded thousands of time from sites around the world.

#### 4.2 NA-MIC-Kit

The NA-MIC Kit and the various components that compose the Kit are receiving wide dissemination as measured from download statistics. The CMake/CTest/CPack software process tools realize approximately 1000 downloads per day from the Kitware site, which does not include other sites and Linux distributions. Other download statistics include:

<b>Slicer3</b>	<b>3,300 unique downloads in the current reporting period</b>
<b>VTK</b>	<b>7,000 per month</b>
<b>ITK</b>	<b>5,000 per month</b>
<b>CMake/CTest/CPack</b>	<b>1,000 per day</b>

The community size, based on mailing list participation, is estimated at tens of thousands of users and hundreds of active developers. This is a testament to the ability of open-source software to leverage development efforts across a broader community, at little additional cost to the project sponsors.

#### 4.3 Outreach and Technology Transfer

Cores 4, 5, and 6 continue to support, train and disseminate to the NA-MIC community, and the broader biomedical computing community.

Project Week continues to be a successful NA-MIC venue. These semi-annual events



are held in Boston in June, and in Salt Lake City in January. These events are well attended with over 100 participants (enrollment is limited), of which about a third are outside collaborators. At the last Project Week in Salt Lake City, Utah, approximately 53 projects were realized.

NA-MIC continues to participate in conferences and other technical venues. For example, NA-MIC hosted the following training venues and workshops:

**Slicer training workshops were held at:**

- Stanford University, jointly hosted with the SIMBIOS and NCBO NCBC sites BWH
- Munich, Germany, NA-MIC Kit workshop co-hosted by NA-MIC
- Presentation at the 8th Annual International Meeting for Autism Research (IMFAR) in Chicago, IL
- NA-MIC Lupus DBP White Matter Lesion Tutorial Release at 2008 Society for Neuroscience Annual Meeting, Washington, DC

**NA-MIC presented several Workshops and a tutorial at MICCAI**

- Workshop: Prostate image analysis and computer-assisted intervention
- Workshop: Systems & architecture for computer-assisted intervention
- Workshop: Segmentation in the Clinic Challenge
- Tutorial: Interfacing third-party software with the NA-MIC Kit Tutorial for Autism DBP: Cortical Thickness Measurement

**4.4 Tutorial for Autism DBP: Cortical Thickness Measurement**

As part of the 2009 NA-MIC All-Hands-Meeting, a "Tutorial Contest" was held with the purpose of enriching the training materials that are available to users and developers of 3D Slicer and the NA-MIC Kit. A secondary goal of this contest is to encourage broad dissemination to the NA-MIC community. The tutorial was judged by a panel of judges from across the Cores, who reviewed submitted entries that addressed one of two areas: An end-to-end solution to a clinical problem; or an algorithm tutorial that shows users how to make an algorithm work with their own data.

The winning entry was the tutorial for the cortical thickness analysis tools developed by the UNC Autism DBP. The UNC submission showed users how to perform analysis of regional cortical thickness. Two tutorials were included in this entry: (1) The ARCTIC tutorial for automatic analysis, in which the user learns how to load input volumes, run the end-to-end module ARCTIC to generate cortical thickness information, and display output volumes, and (2) The Slicer3 tutorial for step-by-step analysis, in which the user learns how to run the individual UNC external modules within Slicer3 and perform a regional cortical thickness analysis.

## 5. IMPACT AND VALUE TO BIOCOMPUTING

NA-MIC impacts the field of biocomputing through a variety of mechanisms. First, NA-MIC produces scientific results, methodologies, workflows, algorithms, imaging platforms, and software engineering tools and paradigms in an open environment that contributes directly to the body of knowledge available to the field. Second, NA-MIC science and technology enables the entire medical imaging community to build on NA-MIC results, methods, and techniques, to concentrate on the new science instead of developing supporting infrastructure, to leverage NA-MIC scientists and engineers to adapt NA-MIC technology to new problem domains, and to leverage NA-MIC infrastructure to distribute its own technology to a larger community.

### 5.1 Impact within the Center

Within the center, NA-MIC has formed a community around its software engineering tools, imaging platforms, algorithms, and clinical workflows. The NA-MIC calendar includes the All Hands Meeting and Winter Project Week, the Spring Algorithm Meeting, the Summer Project Week, Slicer3 Mini-Retreats, Core Site Visits, and weekly telephone conferences. Over the past 18 months, the Engineering Core has visited each algorithm core site to support the specific infrastructure needs of each group.

The NA-MIC software engineering tools (CMake, CDash, CTest, CPack) have enabled the development and distribution of a cross-platform, nightly tested, end-user application, Slicer3, that is a complex union of novel application code, visualization tools (VTK), imaging libraries (ITK, TEEM), user interface libraries (Tk, KWWidgets), and scripting languages (TCL, Python). The NA-MIC software engineering tools have been essential to the development and distribution of the Slicer3 imaging platform to the NA-MIC community.

NA-MIC's end-user application, Slicer3, supports the research within NA-MIC by providing a base application for visualization, image analysis, and data management. Slicer3 supports multiplanar reformat, oblique reformat, surface and volume rendering, comparison viewers, tracked cursors, and multiple image layer blending. Slicer3 can communicate with an XNAT database to download data and upload results. Slicer3 provides a multi-layer plugin mechanism, which permits researchers to quickly and easily integrate and distribute their technology with Slicer3. Plugins can be authored as separate executables, shared libraries, Python scripts, or as full first class Slicer3 modules. These plugins can be distributed with Slicer3 or distributed on a site maintained by the researcher (e.g., on the Neuroimaging Informatics Tools and Resources Clearinghouse). [www.nitrc.org](http://www.nitrc.org) Slicer3 is available to all Center participants and the external community through its source code repository, official binary releases, and unofficial nightly binary snapshots. There are 15 training modules on the Slicer3 User Training 101 webpage, which educate Slicer3 Users on basic image review, use of advanced modules, and integration of new technology into Slicer3.

NA-MIC drives the development of platforms and algorithms through the needs and research of its DBPs. Each DBP has selected specific workflows and roadmaps as focal points for development, with a goal of providing the community with complete end-to-end solutions using NA-MIC tools. The current roadmap projects are Brain Lesion Analysis in Neuropsychiatric Systemic Lupus Erythematosus, Stochastic Tractography for VCSF, Cortical Thickness for Autism, and Prostate Biopsy Needle Positioning Robot

Integration. For each roadmap project, the software tools, exemplar data, and a tutorial are provided to the community to allow others to reproduce the results and apply the workflows in their own research programs. Along with the four roadmap tutorials, five other tutorials were presented at the 2009 Tutorial Contest held at the NA-MIC All Hands Meeting in January 2009.

NA-MIC algorithms are designed and used to address specific needs of the DBPs. Multiple solution paths are explored and compared within NA-MIC, resulting in recommendations to the field. For example, in 2008 and 2009, eight NA-MIC tractography algorithms were evaluated. At the All Hands Meeting in 2008, a distributed group of researchers reported on a qualitative study on tractography methods. At the All Hands Meeting in 2009, the same group reported back on quantitative measures of sensitivity and specificity. The NA-MIC algorithm groups collaborate on a broad spectrum of methods for Structural Image Analysis, Diffusion Image Analysis, and Functional Image Analysis and orchestrate the solutions to the DBP workflows and roadmaps. These efforts have led to fundamental advancements in shape representation, shape analysis, groupwise registration, diffusion estimation, segmentation and quantification, and functional estimation, distortion correction, and clustering.

## **5.2 Impact within NIH-Funded Research**

Within NIH-funded research, NA-MIC is the National Center for Biomedical Computing (NCBC) collaborating center for four R01's: Automated FE Mesh Development, Measuring Alcohol and Stress Interactions with Structural and Perfusion MRI, An Integrated System for Image-Guided Radiofrequency Ablation of Liver Tumors, and Development and Dissemination of Robust Brain MRI Measurement Tools. Several other proposals have been submitted and are under evaluation for the "Collaborations with NCBC PAR" as well as to other NIH calls.

NA-MIC also collaborates on the Slicer3 platform with the NIH-funded Neuroimage Analysis Center (NAC) and the National Center for Image-Guided Therapy (NCIGT). The NIH funded "BRAINS Morphology and Image Analysis" project is also leveraging NA-MIC and Slicer3 technology. A collaboration with the SIMBIOS NCBC is evaluating NA-MIC tools for model generation from diagnostic images. NA-MIC collaborates with the NIH-funded Neuroimaging Informatics Tools and Resources Clearinghouse (NITRC) on distribution of Slicer3 plugin modules. A Slicer3 training session was held at the National Cancer Institute (NCI) in August of 2008. Slicer3 is listed as one of the DICOM Viewers on the National Biomedical Imaging Archive at NCI.

NA-MIC events and tools garner national and international interest. Over 100 researchers participated in the NA-MIC All Hands Meeting and Winter Project Week in January 2009. Many of these participants were outside of NA-MIC and were attending the meetings to gain access to the NA-MIC tools and researchers. These external researchers are contributing ideas and technology back into NA-MIC. Two of the break-out sessions at the Winter Project Week were organized by researchers external to NA-MIC. The Project Week in June of 2009 is being expanded to include NA-MIC, NAC, NCIGT, the Harvard Catalyst, and CIMIT.

### **5.3 National and International Impact**

Components of the NA-MIC kit are used globally. The software engineering tools of CMake, CDash, and CTest are used by many open-source projects and commercial applications. For example, the K Desktop Environment (KDE) for Linux and Unix workstations uses CMake and CTest. KDE is one of the largest open source projects in the world. Many open source projects and commercial products are benefiting from the NA-MIC related contributions to ITK and VTK. Slicer3 was downloaded 3,300 times during the current reporting period. Slicer3 also is being used as an image analysis platform in several fields outside of medical image analysis, in particular, biological image analysis, astronomy, and industrial inspection.

NA-MIC science is recognized by the medical imaging community. There are 149 NA-MIC related publications listed on PubMed. Many of these publications are represented in the most prestigious journals and conferences in the field. Overall, there are 228 publications that acknowledge NA-MIC support. Portions of the DBP workflows and roadmaps already are being used by researchers in the broader community and in the development of commercial products.

NA-MIC sponsored several events to promote NA-MIC tools and methodologies. In 2008 alone, NA-MIC hosted 12 workshops and training sessions at 12 venues, including training sessions at NCI, RSNA, and MICCAI. These workshops and tutorials were individually targeted to meet the specific needs and interests of clinicians, biomedical engineers, or algorithm developers. Two hundred and fifty clinical, biomedical, and algorithm researchers attended these events.

## 6. TIMELINES

The tables in this section document the status of the specific aims for each core since inception of the NA-MIC.

### 6.1 ALGORITHMS CORE

CORE 1 Group	Aim	ALGORITHMS Milestone	TIMELINE Proposed completion	Status
MIT	1	<b>Shape-Based Segmentation</b>		
MIT	1.1	Methods to learn shape representations	Year 2	Complete
MIT	1.2	Shape in atlas-driven segmentation	Year 4	Complete
MIT	1.3	Validate and refine approach	Year 5	Complete
MIT	2	<b>Shape Analysis</b>		
MIT	2.1	Methods to compute statistics of shapes	Year 4	Complete
MIT	2.2	Validation of shape methods on application data	Year 5-6	Complete
MIT	3	<b>Analysis of DTI Data</b>		
MIT	3.1	Fiber geometry	Year 3	Complete
MIT	3.2	Fiber statistics	Year 5-6	Complete, new developments ongoing
MIT	3.3	Validation on real data	Year 5-6	Complete, refinements ongoing
Utah	1	<b>Processing of DTI Data</b>		
Utah	1.1	Filtering of DTI	Year 2	Complete
Utah	1.2	Quantitative analysis of DTI	Year 3	Complete
Utah	1.3	Segmentation of cortex/WM	Year 3	Complete
Utah	1.4	Segmentation analysis of white matter tracts	Year 3	Complete
Utah	1.5	Joint analysis of DTI and functional data	Years 5-6	Ongoing
Utah	2	<b>Nonparametric Shape Analysis</b>	Year 5	Complete
Utah	2.1	Framework in place	Year 3	Complete
Utah	2.2	Demonstration on shape of neuroanatomy (from Core 3)	Year 4	Complete
Utah	2.3	Development for multiobject complexes	Year 4	Complete
Utah	2.4	Demonstration of NP shape representations on clinical hypotheses from Core 3	Years 5-6	Complete, preparing publications
Utah	2.5	Integration into NA-MIC-Kit	Years 5-6	In progress
Utah	2.6	Shape regression	Years 5-6	Complete, validation ongoing
UNC	1	<b>Statistical Shape Analysis</b>		
UNC	1.1	Comparative analysis of shape analysis schemes	Year 2	Complete
UNC	1.2	Statistical shape analysis including patient variables	Years 5-6	Complete, extensions ongoing
UNC	2	<b>Structural Analysis of DW-MRI</b>		
UNC	2.1	DTI tractography tools	Year 4	Complete

UNC	2.2	Geometric characterization of fiber tracts	Year 5	Complete
UNC	2.3	Quantitative analysis of diffusion along fiber tracts	Year 5	Complete
GaTech	1	<b>ITK Implementation of PDEs</b>	Year 2	Complete
GaTech	1.1	Applications to Core 3 (DBP) data	Year 4	Complete
GaTech	1.2	New statistical models	Year 4	Complete
GaTech	2	<b>Integration into Slicer</b>	Years 5-6	Ongoing
MGH	1	<b>Registration</b>	Modified (see AR 2008)	
MGH	2	<b>Group DTI Statistics</b>	Modified (see AR 2008)	
MGH	3	<b>Diffusion Segmentation</b>	Modified (see AR 2008)	
MGH	4	<b>Group Morphometry Statistics</b>	Modified (see AR 2008)	
MGH	5	<b>XNAT Desktop</b>	Years 4-6	
MGH	5.1	Establish requirements for desktop version of XNAT	Years 4-5	Complete
MGH	5.2	Develop implementation plan for prototype	Years 4-5	Complete
MGH	5.3	Implement prototype version	Years 4-5	Complete
MGH	5.4	Implement alpha version	Year 5	Complete
MGH	6	<b>XNAT Central</b>	Years 4-6	
MGH	6.1	Deploy XNAT Central, a public access XNAT host	Years 4-5	Complete
MGH	6.2	Coordinate with NA-MIC sites to upload project data	Years 5-6	Incomplete (ongoing)
MGH	6.3	Continue developing XNAT Central based on feedback from NA-MIC sites	Years 5-6	Complete, refinement ongoing
MGH	7	<b>NA-MIC Kit Integration</b>	Years 4-5	
MGH	7.1	Implement web services to exchange data with Slicer, Batchmake, and other client applications	Years 5-6	Complete, testing ongoing
MGH	7.2	Add XNAT Desktop to standard NA-MIC Kit distribution	Years 5-6	Incomplete, modified
<b>CORE 1</b>		<b>ALGORITHMS</b>		<b>TIMELINE MODIFICATIONS</b>
MGH	7.2	Add XNAT Desktop to standard NA-MIC Kit distribution		Testing is under way and XNAT capabilities will be included in NA-MIC at the end of Year 5 or early in Year 6

## 6.2 ENGINEERING CORE

CORE 2 Group	Aim	ENGINEERING Milestone	TIMELINE Proposed completion	Status
GE	1	<b>Define Software Architecture</b>		
GE	1.1	Object design	Year 1	Complete
GE	1.2	Identify patterns	Year 3	Patterns for processing scalar and vector images, models, fiducials complete. Patterns for diffusion weighted imaging (DWI) complete, fMRI ongoing
GE	1.3	Create frameworks	Year 3	Frameworks for processing scalar and vector images, models, fiducials complete. Frameworks for DW complete, fMRI ongoing
GE	2	<b>Software Engineering Process</b>		
GE	2.1	Extreme programming	Years 1-6	On schedule, ongoing
GE	2.2	Process automation	Year 3	Complete
GE	2.3	Refactoring	Year 3	Complete
GE	3	<b>Automated Quality System</b>		
GE	3.1	DART deployment	Year 2	Complete
GE	3.2	Persistent testing system	Year 5-6	Complete (ongoing support)
GE	3.3	Automatic defect detection	Year 5-6	Complete (ongoing support, revisions)
Kitware	1	<b>Cross-Platform Development</b>		
Kitware	1.1	Deploy environment (Cake, CTest)	Year 1	Complete
Kitware	1.2	DART integration and testing	Year 1	Complete
Kitware	1.3	Documentation tools	Year 2	Complete
Kitware	2	<b>Integration Tools</b>		
Kitware	2.1	File formats/IO facilities	Year 2	Complete
Kitware	2.2	CableSWIG deployment	Years 3-6	Complete (Integration ongoing)
Kitware	2.3	Establish XML schema	Year 4	Complete
Kitware	3	<b>Technology Delivery</b>		
Kitware	3.1	Deploy applications	Year 1-6	Complete (ongoing)
Kitware	3.2	Establish plug-in repository	Year 2	Complete
Kitware	3.3	CPack	Year 4-5	Complete
Isomics	1	NA-MIC Builds of Slicer	Year 2-5	Complete (testing ongoing)
Isomics	1.1	Schizophrenia and DBP interfaces	Year 3-5	Complete

Isomics	2	<b>ITK Integration Tools</b>	Year 3-5	Complete
Isomics	2.1	Experiment control interfaces	Year 2-5	Complete
Isomics	2.2	fMRI/DTI algorithm support	Year 2-5	Complete
Isomics	2.3	New DBP algorithm support	Year 2-6	Ongoing
Isomics	3	<b>Compatible Build Process</b>	Year 1-3	Completed
Isomics	3.1	DART integration and testing	Year 1-2	Completed (ongoing maintenance)
Isomics	3.2	Test scripts for new code	Year 2-5	Ongoing
UCSD	1	<b>Grid Computing--Base</b>	Year 1	Complete
UCSD	1.1	Grid-enabled algorithms	Year 3	First version (Gwiz alpha) available - initial integration with Slicer 3 and execution model
UCSD	1.2	Testing infrastructure	Year 4-6	Complete (ongoing testing)
UCSD	2	<b>Data Grid--Compatibility</b>	Year 2	Complete
UCSD	2.1	Data Grid--Slicer Access	Year 2	Complete
UCSD	3	<b>Data Mediation--Deploy</b>	Year 1	Modified (see Annual Report 2008)
UCLA	1	<b>Debabeler Functionality</b>	Year 1	Modified (see Annual Report 2008)
UCLA	2	<b>SLIPIE Interpretation (Layer 1)</b>	Year 1-2	Modified (see Annual Report 2008)
UCLA	3	<b>SLIPIE Interpretation (Layer 2)</b>	Year 1-2	Modified (see Annual Report 2008)
UCLA	3.1	Developing ITK modules	Year 2	Modified (see Annual Report 2008)
UCLA	4	<b>Integrating SRB (GSI-enabled)</b>	Year 2	Modified (see Annual Report 2008)
UCLA	5	<b>Integrating IDA</b>	Year 2	Modified (see Annual Report 2008)
UCLA	5.1	Integrating external visualization applications	Year 2	Modified (see Annual Report 2008)
UCLA	6	<b>DTI Analysis</b>	Year 3-6	
UCLA	6.1	Implementation of mechanically based DTI analysis in ITK	Year 4	Complete
UCLA	6.2	Integration of command-line module into Slicer	Year 5	Complete
UCLA	6.3	Testing/evaluation of DTI analysis module (pilot study)	Year 5	Ongoing



<b>CORE 2</b>		<b>ENGINEERING</b>	<b>TIMELINE MODIFICATIONS</b>
Isomics	3	Data mediation	Delayed pending integration of databases into NA-MIC infrastructure

### 6.3 DRIVING BIOLOGICAL PROJECTS (DBP) CORE

Core 3 projects submitted RO1 style proposals, as specified in the RFA, and consequently, did not submit timelines

### 6.4 SERVICE CORE

<b>CORE 4 Group</b>	<b>Aim</b>	<b>SERVICE Milestone</b>	<b>TIMELINE Proposed completion</b>	<b>Status</b>
Kitware	1	<b>Implement Development Farms</b>		
Kitware	1.1	Deploy platforms	Year 1	Complete
Kitware	1.2	Communications	Year 1-6	Complete, ongoing
Kitware	2	<b>Establish Software Process</b>		
Kitware	2.1	Secure developer database	Year 1-6	Complete, ongoing
Kitware	2.2	Collect guidelines	Year 1	Complete
Kitware	2.3	Management software submission process	Year 1	Complete
Kitware	2.4	Configure process tools	Year 1	Complete
Kitware	2.5	Survey community	Year 1	Complete
Kitware	3	<b>Deploy NA-MIC Tools</b>		
Kitware	3.1	Toolkits	Year 1	Complete
Kitware	3.2	Integration tools	Year 1	Complete
Kitware	3.3	Applications	Year 1	Complete
Kitware	3.4	Integrate new computing resources	Year 1	Complete
Kitware	4	<b>Provide Support</b>		
Kitware	4.1	Establish support infrastructure	Year 1-6	On schedule, ongoing
Kitware	4.2	NA-MIC support	Year 1	Complete
Kitware	5	<b>Manage NA-MIC Software Releases</b>	Year 1-6	On schedule, ongoing

<b>CORE 4</b>		<b>SERVICE</b>	<b>TIMELINE MODIFICATIONS</b>
Kitware	Aims 2-5	Various	Refined/modified various sub-aims

**6.5 TRAINING CORE**

<b>CORE 5 Group</b>	<b>Aim</b>	<b>TRAINING</b>	<b>TIMELINE Proposed completion</b>	<b>Status</b>
Harvard	1	<b>Formal Training Guidelines</b>		
Harvard	1.1	Functional neuroanatomy	Year 1	Complete
Harvard	1.2	Clinical correlations	Year 1	Complete
Harvard	2	<b>Mentoring</b>		
Harvard	2.1	Programming workshops	Year 1-6	On schedule, ongoing
Harvard	2.2	One-on-one mentoring, Cores 1, 2, 3	Year 1-6	On schedule, ongoing
Harvard	3	<b>Collaborative Work Environment</b>		
Harvard	3.1	Wiki	Year 1	Complete
Harvard	3.2	Mailing lists	Year 1	Complete
Harvard	3.3	Regular telephone conferences	Year 1-6	On schedule, ongoing
Harvard	4	<b>Educational Component for Tools</b>		
Harvard	4.1	Slicer training modules	Year 2-6	Slicer 2.x tutorials complete. More than 10 Slicer 3 tutorials and modules
Harvard	5	<b>Demonstrations and Hands-on Training</b>		
Harvard	5.1	Various workshops and conferences	Year 1-6	On schedule, ongoing
<b>CORE 5</b>		<b>TRAINING</b>	<b>TIMELINE MODIFICATIONS</b>	None

**6.6 DISSEMINATION CORE**

<b>CORE 6 Group</b>	<b>Aim</b>	<b>DISSEMINATION Milestone</b>	<b>TIMELINE Proposed completion</b>	<b>Status</b>
Isomics and BWH	1	<b>Create a Collaboration Methodology for NA-MIC</b>		
Isomics and BWH	1.1	Develop a selection process	Year 1	Complete
Isomics and BWH	1.2	Guidelines to govern the collaborations	Year 1-2	Complete
Isomics and BWH	1.3	Provide on-site training	Year 1-6	Complete for current tools, ongoing for tool refinement
Isomics and BWH	1.4	Develop a web site infrastructure	Year 1	Complete

Isomics and BWH	2	<b>Facilitate Communication Between NA-MIC Developers and Wider Research Community</b>		
Isomics and BWH	2.1	Develop materials describing NA-MIC Technology	Year 1-6	On schedule
Isomics and BWH	2.2	Participate in scientific meetings	Year 2-6	On schedule
Isomics and BWH	2.3	Document interactions with external researchers	Year 2-6	On schedule
Isomics and BWH	2.4	Coordinate publication strategies	Year 3-6	On schedule
Isomics and BWH	3	<b>Develop a Publicly Accessible Internet Resource for Data, Software, Documentation, and Publication of New Discoveries</b>		
Isomics and BWH	3.1	On-line repository of NA-MIC related publications and presentations	Year 1-6	On schedule
Isomics and BWH	3.2	On-line repository of NA-MIC tutorial and training manual	Year 1-6	On schedule
Isomics and BWH	3.3	Index and a Searchable Database	Year 1-2	Complete
Isomics and BWH	3.4	Automated feedback systems that track software downloads	Year 3	Complete

**CORE 6**

**DISSEMINATION**

**TIMELINE MODIFICATIONS**

Dissemination efforts that were ongoing in Year 5 will be extended into the at-cost extension Year 6. The dissemination function is shared between Isomics and BWH

**7. Appendix A: Publications that acknowledge NA-MIC support.**

1. Rathi Y., Michailovich O., Shenton M.E., Bouix S. Directional functions for orientation distribution estimation. *Med Image Anal.* 2009 Jun;13(3):432-44. PMID: 19269242.
2. Blackwell M.L., Farrar C.T., Fischl B., Rosen B.R. Target-specific contrast agents for magnetic resonance microscopy. *Neuroimage.* 2009 Jun;46(2):382-93. PMID: 19385012.
3. Escolar M.L., Poe M.D., Smith J.K., Gilmore J.H., Kurtzberg J., Lin W., Styner M. Diffusion tensor imaging detects abnormalities in the corticospinal tracts of neonates with infantile Krabbe disease. *AJNR. Am J Neuroradiol.* 2009 May;30(5):1017-21. PMID: 19386732.
4. Kawashima T., Nakamura M., Bouix S., Kubicki M., Salisbury D., Westin C., McCarley R., Shenton M. Uncinate fasciculus abnormalities in recent onset schizophrenia and affective psychosis: A diffusion tensor imaging study. *Schizophr Res.* 2009 May;110(1-3):119-126. PMID: 19328656.
3. Goldman A.L., Pezawas L., Mattay V.S., Fischl B., Verchinski B.A., Chen Q., Weinberger D.R., Meyer-Lindenberg A. Widespread reductions of cortical thickness in schizophrenia and spectrum disorders and evidence of heritability. *Arch Gen Psychiatry.* 2009 May;66(5):467-77. PMID: 19414706.
4. Levitt J., Styner M., Niethammer M., Bouix S., Koo M., Voglmaier M., Dickey C., Niznikiewicz M., Kikinis R., McCarley R., Shenton M. Shape abnormalities of caudate nucleus in schizotypal personality disorder. *Schizophr Res.* 2009 May;110(1-3):127-139. PMID: 19328654.
5. O'Donnell L., Westin C., Golby A.J. Tract-based morphometry for white matter group analysis. *Neuroimage.* 2009 Apr 15;45(3):832-44. PMID: 19154790.
6. Postelnicu G., Zollei L., Fischl B. Combined Volumetric and Surface Registration. *IEEE Trans Med Imaging.* 2009 Apr;28(4):508-22. PMID: 19273000.
7. Niethammer M., Zach C., Melonakos J., Tannenbaum A. Near-tubular fiber bundle segmentation for diffusion weighted imaging: segmentation through frame reorientation. *Neuroimage.* 2009 Mar;45(1 Suppl):S123-32. PMID: 19101640.
8. Lee K., Yoshida T., Kubicki M., Bouix S., Westin C., Kindlmann G., Niznikiewicz M., Cohen A., McCarley R., Shenton M. Increased diffusivity in superior temporal gyrus in patients with schizophrenia: A Diffusion Tensor Imaging study. *Schizophr Res.* 2009 Mar;108(1-3):33-40. PMID: 19135872.
9. Feczko E., Augustinack J.C., Fischl B., Dickerson B.C. An MRI-based method for measuring volume, thickness and surface area of entorhinal, perirhinal, and posterior parahippocampal cortex. *Neurobiol Aging.* 2009 Mar;30(3):420-31. PMID: 17850926.

10. Hageman N.S., Toga A.W., Narr K.L., Shattuck D.W. A diffusion tensor imaging tractography algorithm based on Navier-Stokes fluid mechanics. *IEEE Trans Med Imaging*. 2009 Mar;28(3):348-60. PMID: 19244007.
11. Dickerson B.C., Feczko E., Augustinack J.C., Pacheco J., Morris J.C., Fischl B., Buckner R.L. Differential effects of aging and Alzheimer's disease on medial temporal lobe cortical thickness and surface area. *Neurobiol Aging*. 2009 Mar;30(3):432-40. PMID: 17869384.
12. Goodlett C., Fletcher P.T., Gilmore J.H., Gerig G. Group analysis of DTI fiber tract statistics with application to neurodevelopment. *Neuroimage*. 2009 Mar;45(1 Suppl):S133-42. PMID: 19059345.
13. Wake A.K., Oshinski J.N., Tannenbaum A.R., Giddens D.P. Choice of In Vivo Versus Idealized Velocity Boundary Conditions Influences Physiologically Relevant Flow Patterns in a Subject-Specific Simulation of Flow in the Human Carotid Bifurcation. *J Biomech Eng*. 2009 Feb;131(2):021013. PMID: 19102572.
14. Ou W., Hämäläinen M.S., Golland P. A distributed spatio-temporal EEG/MEG inverse solver. *Neuroimage*. 2009 Feb 1;44(3):932-46. PMID: 18603008.
15. Zhang F., Hancock E.R., Goodlett C., Gerig G. Probabilistic white matter fiber tracking using particle filtering and von Mises-Fisher sampling. *Med Image Anal*. 2009 Feb;13(1):5-18. PMID: 18602332.
16. Lindig T.M., Kumar V., Kikinis R., Pieper S., Schrödl F., Neuhuber W.L., Brehmer A. Spiny versus stubby: 3D reconstruction of human myenteric (type I) neurons. *Histochem Cell Biol*. 2009 Jan;131(1):1-12. PMID: 18807064.
17. Fitzsimmons J., Kubicki M., Smith K., Bushell G., San José Estepar R., Westin C., Nestor P., Niznikiewicz M., Kikinis R., McCarley R., Shenton M. Diffusion tractography of the fornix in schizophrenia. *Schizophr Res* 2009 Jan; 107:39–46. PMID: 19046624.
18. Goodman A.A., Rosolowsky E.W., Borkin M.A., Foster J.B., Halle M., Kauffmann J., Pineda J.E. A role for self-gravity at multiple length scales in the process of star formation. *Nature*. 2009 Jan 1;457(7225):63-6. PMID: 19122636.
19. Pace D., Oguro S., Haker S., Hata N. MR-guided prostate interventions with 3D Slicer and the NA-MIC Kit. *NCIGT-SNR Tutorial*. 2009 January;
20. Xia T., Baird C., Jallo G., Hayes K., Nakajima N., Hata N., Kazanzides P. An integrated system for planning, navigation and robotic assistance for skull base surgery. *Int J Med Robot*. 2008 Dec;4(4):321-30. PMID: 18803337.
21. U-Thainual P., Fischer G., Lordachita I., Vikal S., Fichtinger G. The Perk Station: systems design for percutaneous intervention training suite. *Proceedings of the IEEE International Conference on Robotics and Biomimetics (ROBIO) 2008*.

22. Rehman T.U., Haber E., Pryor G., Melonakos J., Tannenbaum A. 3D Nonrigid Registration via Optimal Mass Transport on the GPU. *Med Image Anal.* 2008 PMID: 19135403.
23. Makris N., Angelone L., Tulloch S., Sorg S., Kaiser J., Kennedy D., Bonmassar G. MRI-based anatomical model of the human head for specific absorption rate mapping. *Med Biol Eng Comput.* 2008 Dec;46(12):1239-51. PMID: 18985401.
24. Kubicki M., Styner M., Bouix S., Gerig G., Markant D., Smith K., Kikinis R., McCarley R.W., Shenton M.E. Reduced interhemispheric connectivity in schizophrenia-tractography based segmentation of the corpus callosum. *Schizophr Res.* 2008 Dec;106(2-3):125-31. PMID: 18829262.
25. Khachaturian M.H., Arsenault J., Ekstrom L.B., Tuch D.S., Vanduffel W. Focal reversible deactivation of cerebral metabolism affects water diffusion. *Magn Reson Med.* 2008 Nov;60(5):1178-89. PMID: 18958855.
26. Lankton S., Tannenbaum A. Localizing region-based active contours. *IEEE Trans Image Process.* 2008 Nov;17(11):2029-39. PMID: 18854247.
27. Pace D., Hata N. Image Guided Therapy in Slicer3: Planning for Image Guided Neurosurgery. *NCIGT-SNR Tutorial.* 2008 November.
28. Hinds O.P., Polimeni J.R., Rajendran N., Balasubramanian M., Wald L.L., Augustinack J.C., Wiggins G., Rosas H.D., Fischl B., Schwartz E.L. The intrinsic shape of human and macaque primary visual cortex. *Cereb Cortex.* 2008 Nov;18(11):2586-95. PMID: 18308709.
29. Dambreville S., Yezzi A., Lankton S., Tannenbaum A. TAC: Thresholding active contours. *Proceedings of the IEEE International Conference on Image Processing 2008.*
30. Yeo B.T.T., Sabuncu M.R., Desikan R., Fischl B., Golland P. Effects of registration regularization and atlas sharpness on segmentation accuracy. *Med Image Anal.* 2008 Oct;12(5):603-15. PMID: 18667352.
31. Aja-Fernandez S., Niethammer M., Kubicki M., Shenton M.E., Westin C. Restoration of DWI data using a Rician LMMSE estimator. *IEEE Trans Med Imaging.* 2008 Oct;27(10):1389-403. PMID: 18815091.
32. Gouttard S., Styner M., Prastawa M., Piven J., Gerig G. Assessment of Reliability of Multi-site Neuroimaging Via Traveling Phantom Study. *Int Conf Med Image Comput Comput Assist Interv.* 2008;11(Pt 2):263-270. PMID: 18982614.
33. Ou W., Golland P., Hamalainen M. A Distributed Spatio-temporal EEG/MEG Inverse Solver. *Int Conf Med Image Comput Comput Assist Interv.* 2008;11(Pt 1):26-34. PMID: 18979728.
34. Lashkari D., Vul E., Kanwisher N., Golland P. Discovering Structure in the Space of Activation Profiles in fMRI. *Int Conf Med Image Comput Comput Assist Interv.* 2008;11(Pt1):1016-1024. PMID: 18979845.

35. Goodlett C., Fletcher P.T., Gilmore J.H., Gerig G. Group Statistics of DTI Fiber Bundles Using Spatial Functions of Tensor Measures. *Int Conf Med Image Comput Comput Assist Interv.* 2008;11(Pt1):1068-1075. PMID: 18979851.
36. Balci S.K., Sabuncu M.R., Yoo J., Ghosh S., Whitfield-Gabrieli S., Gabrieli J.D.E., Golland P. Prediction of successful memory encoding from fMRI data. *Proceedings of the First Workshop on Analysis of Functional Medical Images, Int Conf Med Image Comput Comput Assist Interv.* 2008; 97-104.
37. Ziyen U., Westin C. Joint Segmentation of Thalamic Nuclei from a Population of Diffusion Tensor MR Images. *Int Conf Med Image Comput Comput Assist Interv.* 2008;11(Pt 1):279-286. PMID: 18979758.
38. Rehman T.U., Haber E., Pohl K.M., Haker S., Halle M., Talos F., Wald L.L., Kikinis R., Tannenbaum A. Multimodal Registration of White Matter Brain Data via Optimal Mass Transport. *Proceedings of the Third Workshop on Computational Biomechanics for Medicine (CBM'08), Int Conf Med Image Comput Comput Assist Interv.* 2008; 27-36.
39. Mohan V., Sundaramoorthi G., Melonakos J., Niethammer M., Kubicki M., Tannenbaum A. Tubular Surface Evolution for Segmentation of the Cingulum Bundle From DW-MRI. *Proceedings of the Second Workshop on Mathematical Foundations of Computational Anatomy (MFCA'08), Int Conf Med Image Comput Comput Assist Interv.* 2008.
40. Van Leemput K., Bakkour A., Benner T., Wiggins G., Wald L.L., Augustinack J., Dickerson B.C., Golland P., Fischl B. Model-Based Segmentation of Hippocampal Subfields in Ultra-High Resolution In Vivo MRI. *Int Conf Med Image Comput Comput Assist Interv.* 2008;11(Pt 1):235-245. PMID: 18979753.
41. Poynton C., Jenkinson M., Whalen S., Golby A.J., Wells III W. Fieldmap-Free Retrospective Registration and Distortion Correction for EPI-Based Functional Imaging. *Int Conf Med Image Comput Comput Assist Interv.* 2008;11(Pt 2):271-279. PMID: 18982615.
42. Tokuda J., Fischer G.S., Csoma C., DiMaio S.P., Gobbi D.G., Fichtinger G., Tempny C.M., Hata N. Software Strategy for Robotic Transperineal Prostate Therapy in Closed-Bore MRI. *Int Conf Med Image Comput Comput Assist Interv.* 2008;11(Pt 2):701-709. PMID: 18982666.
43. Yeo B.T.T., Sabuncu M., Vercauteren T., Ayache N., Fischl B., Golland P. Spherical Demons: Fast Surface Registration. *Int Conf Med Image Comput Comput Assist Interv.* 2008;11(Pt 1):745-753. PMID: 18979813.
44. Cates J., Fletcher P.T., Styner M., Hazlett H.C., Whitaker R. Particle-Based Shape Analysis of Multi-object Complexes. *Int Conf Med Image Comput Comput Assist Interv.* 2008;11(Pt 1):477-485. PMID: 18979781.

45. Yeo B.T.T., Yu P., Grant P.E., Fischl B., Golland P. Shape Analysis with Overcomplete Spherical Wavelets. *Int Conf Med Image Comput Comput Assist Interv.* 2008;11(Pt 1):468-476. PMID: 18979780.
46. Sabuncu M.R., Balci S.K., Shenton M.E., Golland P. Discovering Modes of an Image Population through Mixture Modeling. *Int Conf Med Image Comput Comput Assist Interv.* 2008;11(Pt 2):381-389. PMID: 18982628. PMCID: PMC2671151
47. Le Faucheur X., Brani V., Delphine N., Tannenbaum A. Adaptive Bayesian Shrinkage Model for Spherical Wavelet Based Denoising and Compression of Hippocampus Shapes. *Proceedings of the Workshop on Computational Anatomy and Physiology of the Hippocampus (CAPH'08), Int Conf Med Image Comput Comput Assist Interv.* 2008; 87–96.
48. Malcolm J., Rathi Y., Shenton M.E., Tannenbaum A. Label Space: A Coupled Multi-shape Representation. *Int Conf Med Image Comput Comput Assist Interv.* 2008;11(Pt 2):416-424. PMID: 18982632.
49. Dambreville S., Rathi Y., Tannenbaum A. A framework for image segmentation using shape models and kernel space shape priors. *IEEE Trans Pattern Anal Mach Intell.* 2008 Aug;30(8):1385-99. PMID: 18566493.
50. Fischl B., Rajendran N., Busa E., Augustinack J., Hinds O., Yeo B.T.T., Mohlberg H., Amunts K., Zilles K. Cortical Folding Patterns and Predicting Cytoarchitecture. *Cereb Cortex.* 2008 Aug;18(8):1973-80. PMID: 18079129. PMCID: PMC2474454.
51. Michailovich O.V., Tannenbaum A. Fast approximation of smooth functions from samples of partial derivatives with applications to phase unwrapping. *IEEE Signal Processing* 2008; 88:358-374.
52. U-Thainual P., Lordachita I., Fichtinger G. The Perk Station: Design of a percutaneous intervention training suite. *Proceedings of the 20th International Conference of the Society for Medical Innovation and Technology (SMIT),* 2008; pp. 148-153.